

AlphaNET™

version 3.0

**Compatible with
Windows 95, 98, NT, ME, 2000, XP, Vista
& Macintosh PowerPCs!**

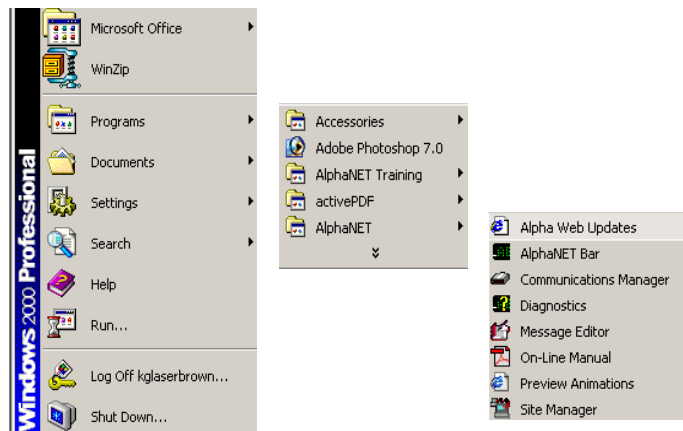

User Manual

ADAPTIVE®

© 1996 - 2007 Adaptive Micro Systems, Inc.
Form No. 97088081 rev.H
Revision date: October 15, 2007

Manual Map

1

Connecting your PC to a sign



This chapter explains the basics of connecting your personal computer to a sign.

2

Installing AlphaNET™ 3.0
and setting up sites



This chapter shows you how to install the AlphaNET™ 3.0 software on your personal computer.

Also, a step-by-step tutorial explains the basics of creating sites using *Site Manager*.

3 **Creating and sending messages**



This chapter explains how to create and send messages with *Message Editor*, as well as how to include graphics and animation in your messages.

4 **Reference**



This chapter contains quick reference summaries of *Message Editor*, *Site Manager*, *Communications Manager*, and *Diagnostics* in the AlphaNET™ 3.0 software.

© Copyright 2007 Adaptive Micro Systems LLC. All rights reserved.
Adaptive Micro Systems
7840 North 86th Street
Milwaukee, WI 53224 USA
414-357-2020
414-357-2029 (fax)
<http://www.adaptivedisplays.com>

Adaptive is a registered trademark of Adaptive Micro Systems. AlphaNET is a trademark of Adaptive Micro Systems. All other brand and product names are trademarks or registered trademarks of their respective companies.

What's new in AlphaNET™ version 3.0 software

Password protection

Site Manager and Message Editor can now be password-protected. Select *Set Password* from the *Edit* drop-down menu:

Type a new password in the *New Password* line, then press *Tab*. Type the same password in the *Verify* box and click *OK*.

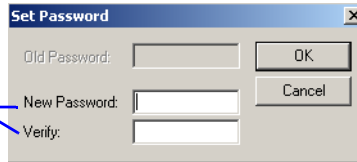

When changing the password, you must first type the password to be changed in the *Old Password* line.

Menu customization

You can customize the options appearing in the drop-down menus in Message Editor by selecting *Edit>Customize*:

The type of sign selected determines the options available in your drop-down menus.

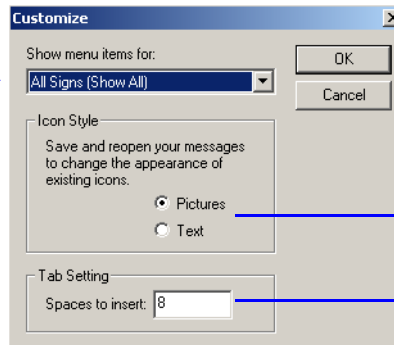

Select how you want the icons in your messages to appear, as pictures or as text.

Type the number of spaces to insert for a tab setting.

Color selection

A new color selection box is available for the AlphaEclipse™ Purecolor™ 3600 series sign (full color, not monochrome). In Message Editor, see *Characters>Color>RGB*.

This color selection box also appears when you select *Characters>Shadow* in Message Editor to allow you to pick the shadow color of the characters.



New modes

Two new modes are available with this version of AlphaNET™, Clock mode and Explode mode. Clock mode is a wipe mode that updates information as if a second hand were sweeping around the sign. Explode mode is a roll mode that moves information from the center of the sign and outward in all four directions at once. Both modes are available in Message Editor under the *Modes* drop-down menu.

New line positions

Two new line positions are available in *Message Editor*, Left and Right, which left- or right-justify your message.

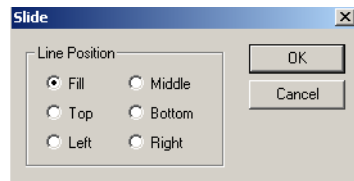

These line positions are only available with the AlphaEclipse™ PureColor™ 3600 series sign.

Tooltips

Tooltips are now available in all components of AlphaNET 3.0.

A Tooltip appears when you place the mouse over an icon in any component of AlphaNET.

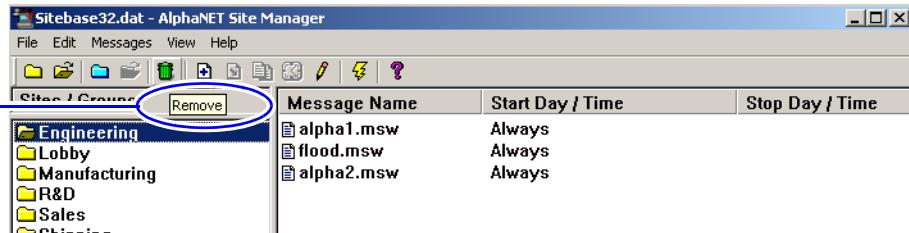

Contents

- Manual Map 2**
- What's new in AlphaNET™ version 3.0 software 5**
 - Password protection.....5
 - Menu customization5
 - Color selection.....5
 - New modes.....6
 - New line positions6
 - Tooltips.....6

- 1 Connecting your PC to a sign 9**
 - PC hardware and software requirements.....10
 - Minimum hardware and software requirements10
 - Other hardware requirements.....10
 - Macintosh® hardware and software requirements.....10
 - Related documentation10
 - Types of sign connections11
 - Cable network.....11
 - Modem network11
 - Wireless network.....12
 - Local Area Network (LAN)12

- 2 Installing AlphaNET™ 3.0 software and setting up sites 13**
 - How to install AlphaNET™ 3.0 software.....14
 - How to change a sign's serial address.....15
 - What is a serial address?.....15
 - Changing a sign's serial address16
 - Step-by-step tutorial in setting up connection devices, sites, and groups17
 - What are sites and groups.....17
 - Overview of the tutorial.....17
 - Step 1: Creating or changing the connection devices19
 - Setting up a modem (remote) connection20
 - Setting up a cable (local) connection23
 - Setting up a wireless transmitter connection25
 - Setting up a Local Area Network (LAN) connection.....27
 - Step 2: Creating or changing the sites29
 - Creating the R & D Site — a modem example29
 - Creating the Sales Site — a LAN example.....33
 - Creating the Lobby, Engineering, and Manufacturing sites — a wired example.....36
 - Creating the Shipping site — a wireless example.....40
 - Step 3: Creating or changing the groups43

3	Creating and sending messages	47
	Basic message editing	48
	Using Message Editor to create your message	48
	Using modes to change the look of a message	51
	Using characters to change the look of a message	54
	Using international characters	59
	How to send a message to a sign	62
	What happens when messages are sent to a sign?	62
	Sending messages from Message Editor	63
	Sending messages from Site Manager	64
	The difference between all messages and common messages	65
	How to use graphics in messages	66
	Creating a graphic	66
	Creating a flick	71
	Another way to create a flick	76
	Creating a GIF	77
	How to edit a counter file	81
	What is a counter file?	81
	Three examples of how to use counter files	82
	Example 1 — Using a counter in a message	83
	Example 2 — Using a counter in a message and displaying a target file message	90
	Example 3 — Using a counter to display just a target message	99
	How to use real-time data in a message	103
	String Variables + ActiveX® = real-time data	103
	Real-time data example	103
	Create sign memory configurations using Site Manager	103
	Create a message with a string variable using Message Editor	104
	Update the sting variable using the ActiveX® control	105
	How to create and use a custom Automode sequence	107
	Creating or editing an Automode sequence	107
	Using a custom Automode sequence	108
4	Reference	111
	Message Editor	112
	Site Manager	120
	Communications Manager	126
	Diagnostics	128
5	Appendices	135
	Appendix A — Macintosh® computer setup	136
	Appendix B — Modes available on signs	137
	Appendix C — Character fonts and colors available on signs	139
	Appendix D — Display Options available on signs	140
	Appendix E — Understanding message line positions (Top, Middle, Bottom, Fill)	141
	Appendix F — How text and graphics are displayed on signs	147

1

Connecting your PC to a sign

PC hardware and software requirements

Minimum hardware and software requirements

- Windows® 95, 98, NT Workstation, ME, 2000, XP, or Vista software
- Processor requirements appropriate to selected operating system
- 16 MB RAM
- 10 MB of hard disk space
- CD drive
- RS232 (serial port) or LAN access
- Works with Alpha® displays

Other hardware requirements

Additional hardware, such as connectors and cabling, is also required and depends on the type of sign and connection you will be using.

Macintosh® hardware and software requirements

See “Appendix A — Macintosh® computer setup” on page 136 for details.

Related documentation

The following documentation may be useful with this manual:

Part #	Document name	Description
97000112	Networking Alpha Signs	Explains the various types of sign networking options available.
97088061	Alpha® Sign Communications Protocol	Explains the native protocol used to send text and graphics to Alpha® signs.
97088099	How to Install AlphaNET™ 3.0 Software	Describes how to install the AlphaNET™ 3.0 software and use the Site Wizard.
1179610601	Quick Start: Getting started with AlphaNET	Explains how to quickly connect your sign, install AlphaNET and send messages.

Types of sign connections

An overview of the methods of connecting signs is presented on the following pages.

For more detailed information, see the **Networking Alpha Signs** manual (pn 97000112).

Cable network

In this type of network, one or more signs are connected with RS485 cabling to a PC running AlphaNET™ software:

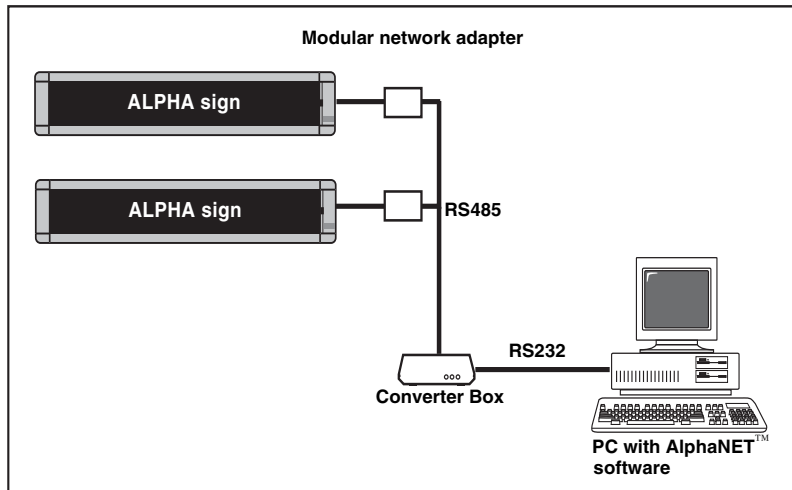

Modem network

In this configuration, modems are used to connect one or more signs to a PC running AlphaNET™ software:

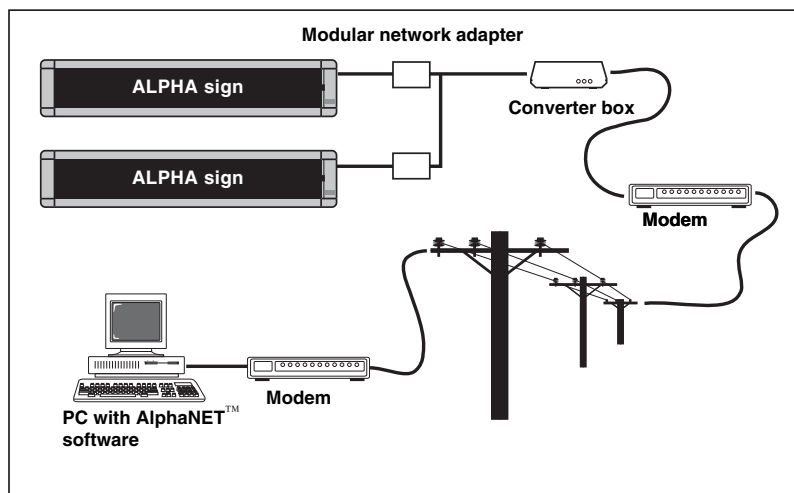

Wireless network

AlphaNET™ 3.0 software can send messages to Alpha® signs on wireless networks. For recommended wireless solutions contact Adaptive Micro Systems at 1-800-719-2838.

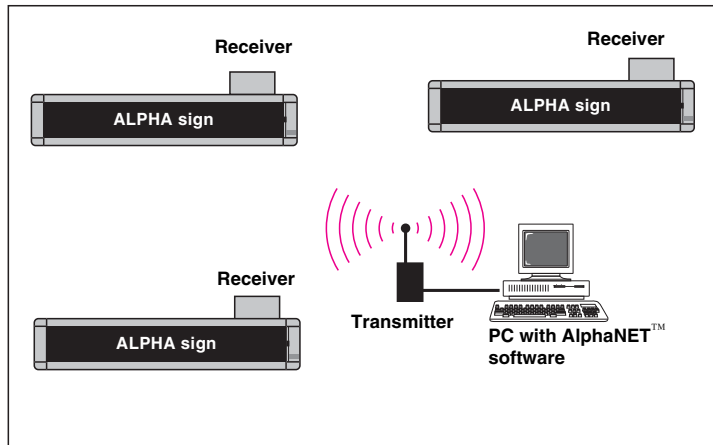

Local Area Network (LAN)

In this configuration, one or more signs are connected to an Ethernet network:

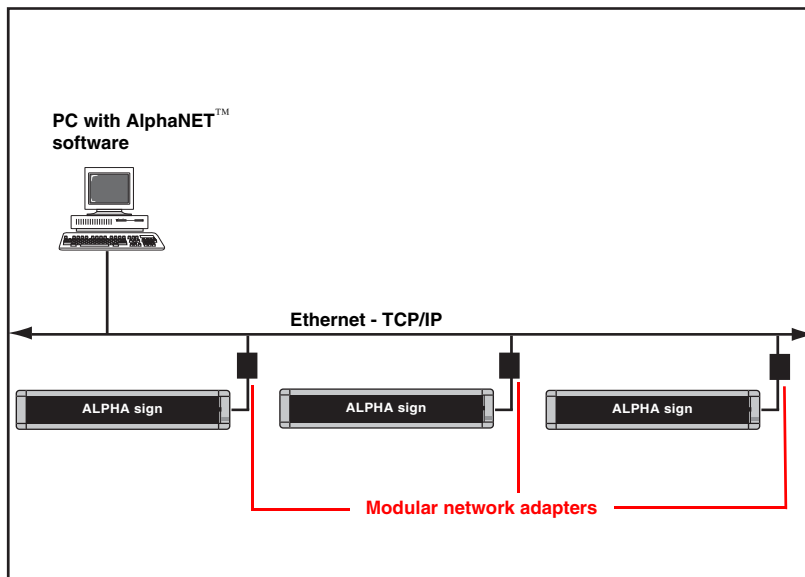

2

Installing AlphaNET™ 3.0 software and setting up sites

How to install AlphaNET™ 3.0 software

HINT

Before starting the software installation, check to see if there is a README file.

Look at this file before installing the software because it may contain late-breaking information.

About the Installation

You will be able to choose to install Adobe Acrobat Reader. Simply click the appropriate yes or no response when the prompt to do so appears.

You will also be able to choose whether you want to install the AlphaNET™ computer based training. If so, it will appear in your *Start>Programs* menu.

A Site Wizard will be available to you to help you set up your first site. It will not appear until you have restarted your computer after the installation. Simply click the appropriate response when the prompt to do so appears. For more information on the Site Wizard or on installing AlphaNET™ 3.0, see **How to install AlphaNET™ 3.0 software (pn 9708-8099)**.

HINT

Right-click anywhere in this area of the AlphaNET™ bar and select *Change Skin* to choose a different color for the bar.

1. Start Microsoft Windows® software and be sure to have all other applications closed.
2. Insert the AlphaNET™ 3.0 software CD-ROM into your CD drive. The installation process will start automatically.

If installation does not start automatically, you can either:

- Select *Start>Run*. Next, type *d:\setup* using the correct letter for your CD drive if not *d*. Finally, select *OK*.

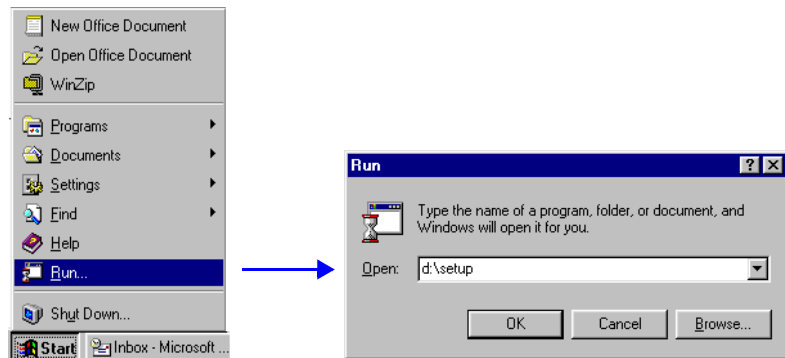

- Or, using Windows® Explorer, double-click *Setup.exe* in your CD-ROM drive folder.
3. Follow the instructions when the installation program prompts you for a response.
 4. When the installation program is complete, AlphaNET™ appears in your *Start* menu. If you select the AlphaNET™ bar, you will have access to *Message Editor*, *Site Manager*, and *Communications Manager* at the click of a button.

Note: If you chose the appropriate box in the installation process, the AlphaNET™ bar will appear automatically when you log into your PC.

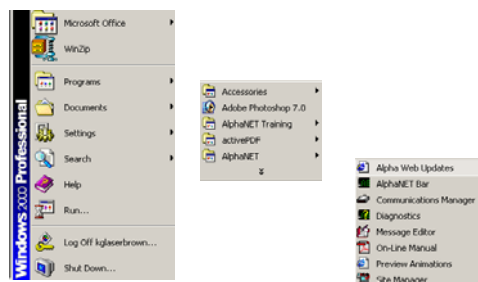

How to change a sign's serial address

What is a serial address?

About Address 00

If more than one sign will be connected to a connection device (modem, wireless, or local connection), then give each sign a unique address, such as 01, 02, 03, and so on.

Otherwise, sending a message to the sign with address 00 will also send the message to *all* other connected signs.

An Alpha® sign has a feature which allows a unique number or serial address (address, for short) to be assigned to the sign. This address permits you to send messages to an individual sign on a network.

All Alpha® signs leave the factory with a default address of 00. However, another address—such as 01, 02, 03, and so on—can be given to a sign. Addresses for signs should be assigned using either a remote control or through the *Diagnostics* component of the AlphaNET™ software. Addresses should also be assigned before setting up connection devices, sites, and groups so that messages go to the correct signs.

For example, at the company used in the next sections's tutorial, several signs are connected to a network (below), and each of these signs is given a unique address so a message can be sent to a particular sign:

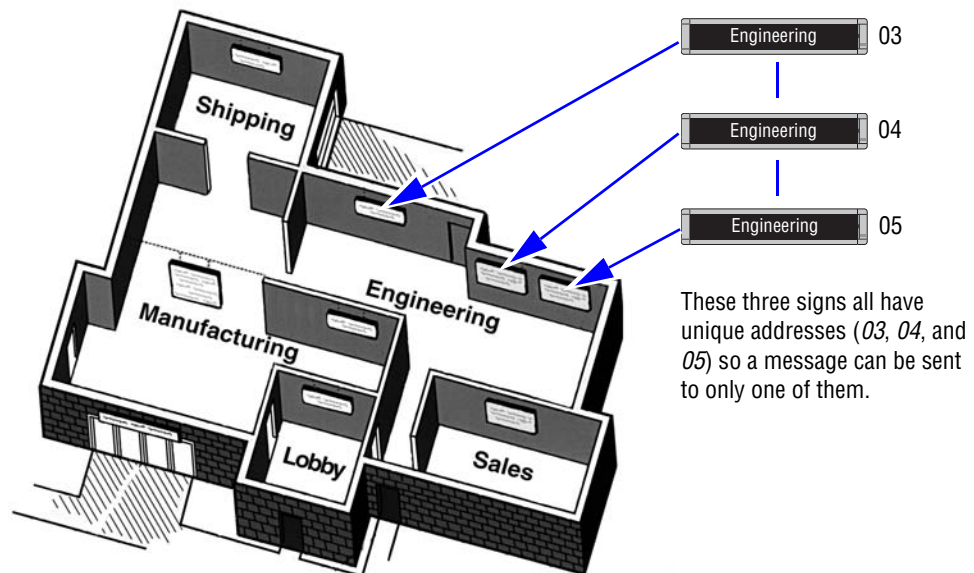

Changing a sign's serial address

NOTE

For some signs, like the 9000 series, AlphaVision™, AlphaPremiere™, and AlphaEclipse™ displays, internal DIP switches must be set to change the serial address.

1. To change the address of a particular sign, first make sure that sign is connected to a power supply and is functioning.
2. Point the front of the remote control at the sign's infrared receiver window as shown below:



Point the front of the remote control at the sign's infrared receiver window.

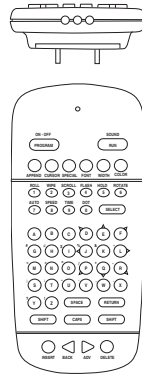

Remote control (front and top views).

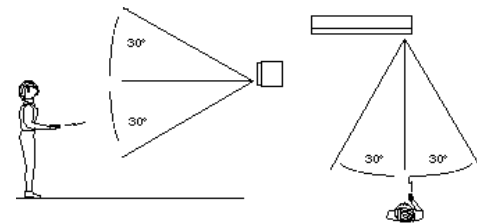

The person using the remote control should be from 5 to 30 feet from the front of the sign.

3. Press the **PROGRAM** button on the remote control. PROG TEXT FILE A will appear on the sign.
4. Next, press the **BACK** button until SET ADDRESS appears.
5. Press the **ADV** button until ADDRESS = 00 appears. (The sign may have an address other than 00.)
6. Set the sign's address by pressing any of the number keys. For example, to enter an address of 15, press the **1** button and then the **5** button.
7. Finally, press the **RUN** button *two* times to set the sign's new address.

Address Note

Normally, a sign's address is a *decimal* number from 00 to 99.

However, if you need more addresses, a *hexadecimal* number from 00 to FF (0 to 255) can be used as an address. For example, hexadecimal 1F = decimal 31.

Step-by-step tutorial in setting up connection devices, sites, and groups

What are sites and groups?

Sites and groups are terms used by AlphaNET™ 3.0 software to describe how messages are sent to signs. You create sites and groups to make sending messages to multiple signs flexible and easy.

A site in AlphaNET™ 3.0 software is a collection of one or more signs, and a group is made up of one or more sites.

To help you better understand, a tutorial is presented below. In this tutorial, a complex example is created in a series of easy-to-understand steps.

Overview of the tutorial

In this tutorial, we'll set up sites and groups for an imaginary company pictured below. The table shows how signs are assigned in this company:

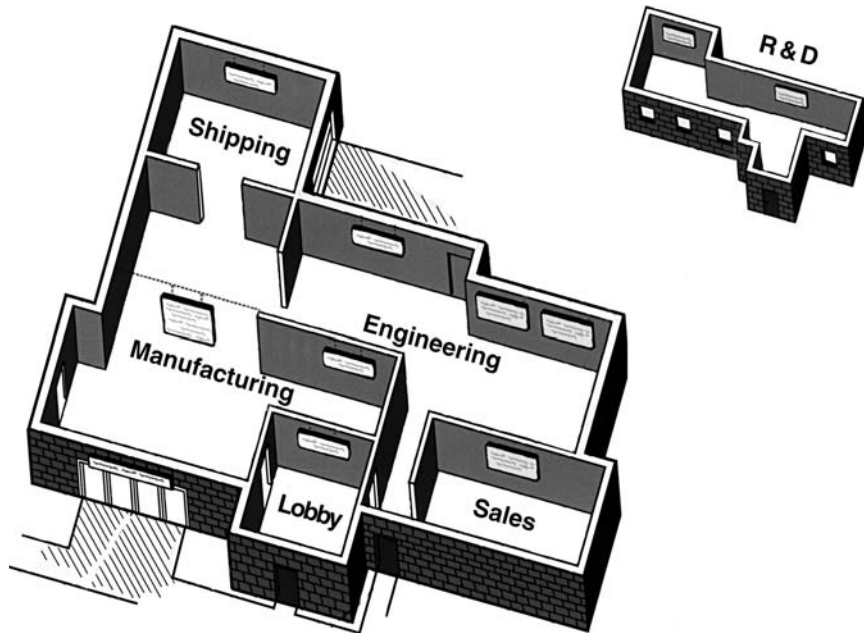
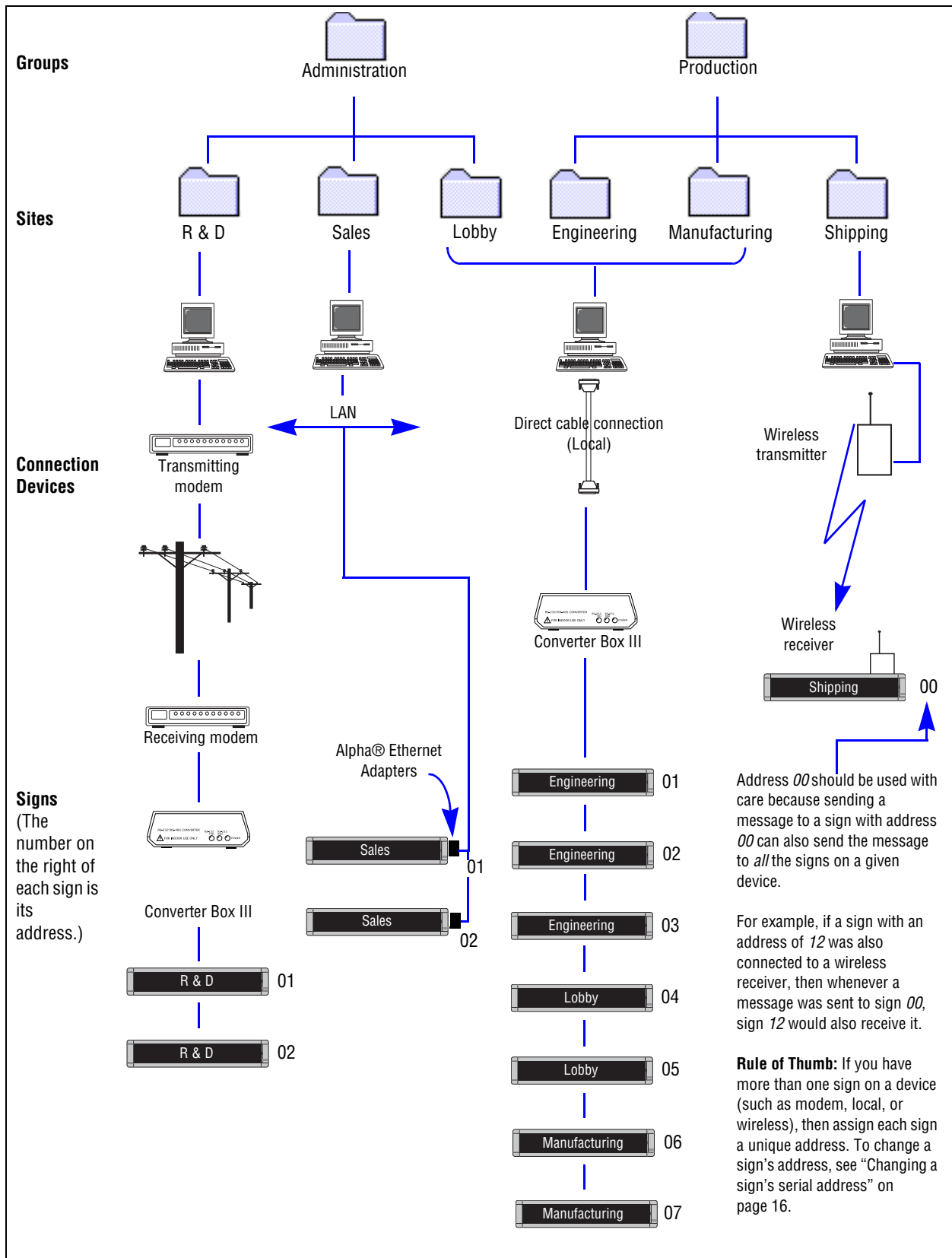

Table 1: Overview of the tutorial company

Group	Site	# signs	¹ Connection Device
Production	Manufacturing	2	• local
	Shipping	1	• wireless
	Engineering	3	• local
Administration	Sales	2	• LAN
	Lobby	2	• local
	R & D	2	• modem

¹A sign is connected to a PC running AlphaNET™ 3.0 software by a direct cable (local) connection, by a modem (remote) connection, or by a wireless transmitter.

Table 2: Schematic of the tutorial company



Step 1: Creating or changing the connection devices

A connection device is a way to connect a sign to a PC that is running AlphaNET™ 3.0 software.

See chapter 1 for instructions on how to connect signs.

For more detailed information on networking signs, see the **Networking Alpha Signs** manual (pn 9700-0112).

The basic devices or types of networks are:

- **Cable (local) connection** — This method uses cables/RS485 to connect signs to a network, and messages one or all sign are sent over this cabling. A local connection works best when all the signs are in one building.
- **Modem (remote) connection** — Typically, this method is used when the signs you want to send messages to are not in the same building (or city) as your PC. In this type of connection, a modem is attached to your PC and another modem is attached to one or more signs at the other location. At the times you specify, messages are transmitted to the signs when the PC modem calls the sign's modem.
- **Wireless connection** (indoor signs) — In this setup, a transmitter is attached to the PC running AlphaNET™ 3.0 software, and each sign is equipped with a wireless receiver. This allows text and graphics to be sent wirelessly to the signs. Note that AlphaEclipse™ signs use a pair of transceivers for 2-way communication. Setup in AlphaNET™ uses a “wired” connection device.
- **Local Area Network (LAN) connection** — This option allows you to connect one or more signs to a LAN using Alpha® Ethernet Adapters. There is no maximum to the number of Alpha® Ethernet Adapters that can be used with AlphaNET™ 3.0 software.

Setting up a modem (remote) connection

In our imaginary company, the following signs are connected by modem:

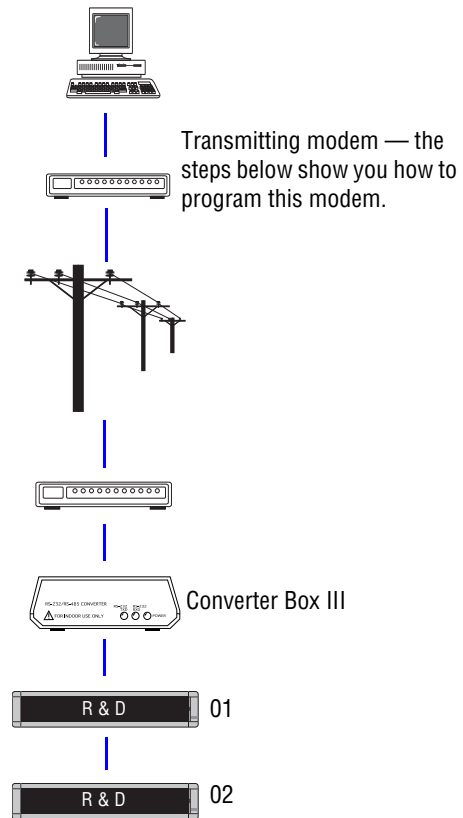

1. To create a modem connection device, open *Site Manager* by selecting either the *Site Manager* button from the AlphaNET™ bar or *Programs>AlphaNET>Site Manager* from the *Start* menu:



2. Select *Edit > Connection Device*:

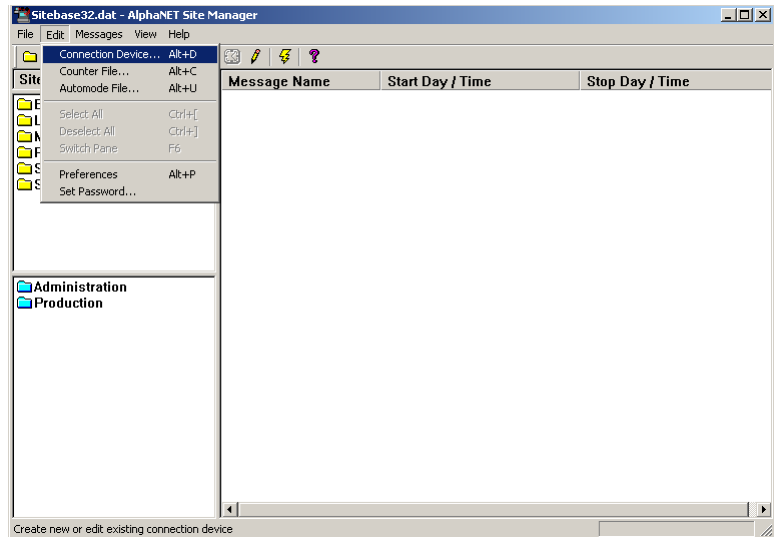

3. When the *Connection Device Editor* window appears, select *Add*. Then select *Modem on Com 1* from the list, followed by *OK*. (If you have a modem on a different communications port, choose the modem on that port.)

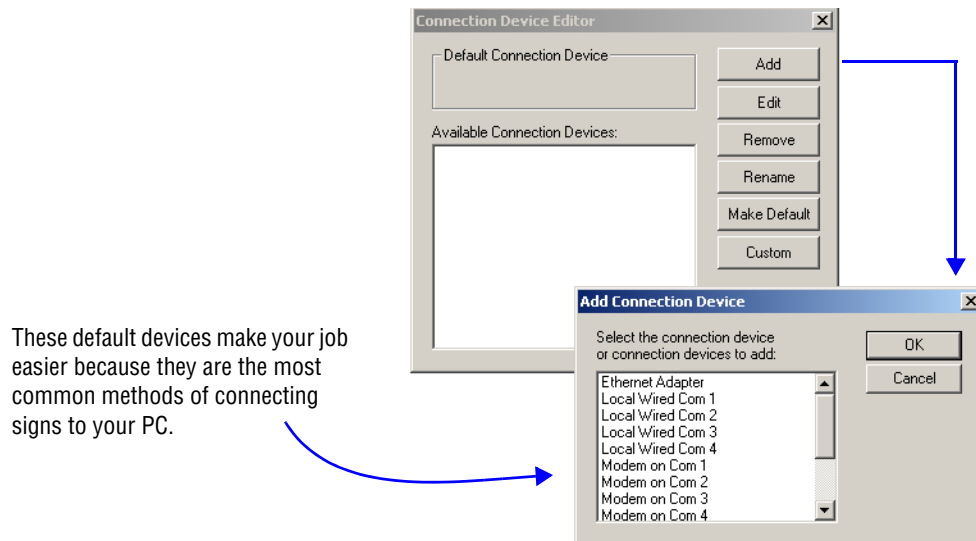

4. Once you select *OK*, the following window appears:

NOTE

To finish setting up a modem connection, you have to create a modem site using *Site Manager*.

To see an example of this, see “Creating the R & D site — a modem example” on page 29.

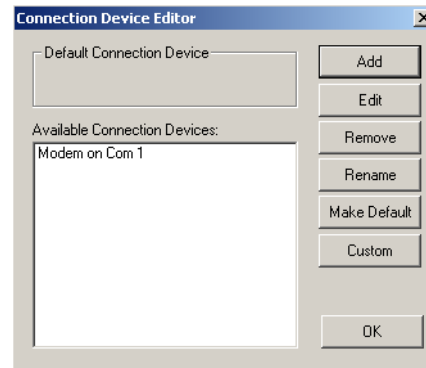

5. If you want to change any of the modem settings, make sure *Modem on Com 1* is highlighted as above and then select *Edit*. Use the following window to change the settings and then select *OK*:

Table 3: Modem setup

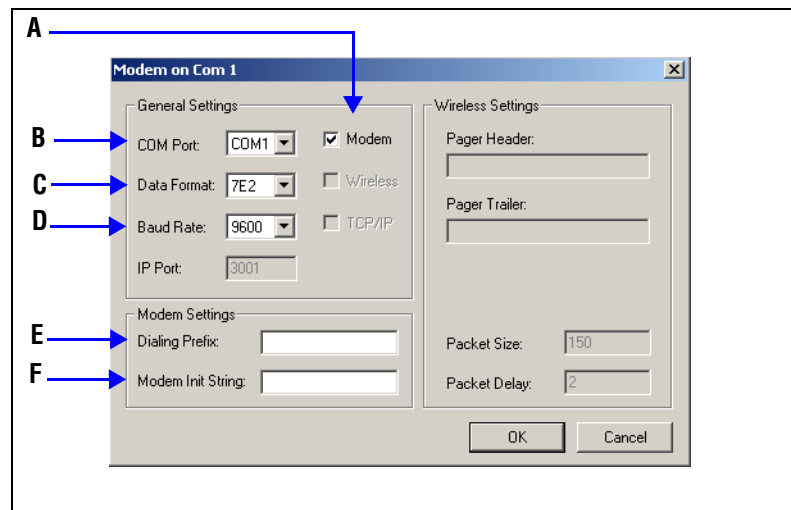

Item	Name	Directions
A	Modem	Check this box.
B	COM Port	Select the port on your PC that connects to your modem.
C	Data Format	Use <i>7E2</i> for 7 data bits, even parity, 2 stop bits. Use <i>8N1</i> for 8 data bits, no parity, 1 stop bit. (The <i>7E2</i> setting is compatible with most signs, but <i>8N1</i> must be used with an AlphaEclipse™ 3500 sign.)
D	Baud Rate	Alpha® signs can receive at baud rates between 1200 and 9600 baud. Only AlphaPremiere™ signs can use the 38400 baud setting.
E	Dialing Prefix	If you must dial a number (such as 9) for your modem to reach an outside phone line, enter the number here. Leave blank with an AlphaEclipse™ 3500 sign.
F	Modem Init String	Consult your modem documentation. Leave blank with an AlphaEclipse™ 3500 sign.

BAUD RATE LIMITS

A Converter Box III with a serial number greater than AF00004525 (for example, AF00004526, AF00004527, and so on) has a minimum baud rate of 2400. Baud rates of 300 or 1200 will not be accepted, even though these rates are shown in *Connection Device Editor*.

Setting up a cable (local) connection

In our imaginary company, the following signs are connected by a local connection:

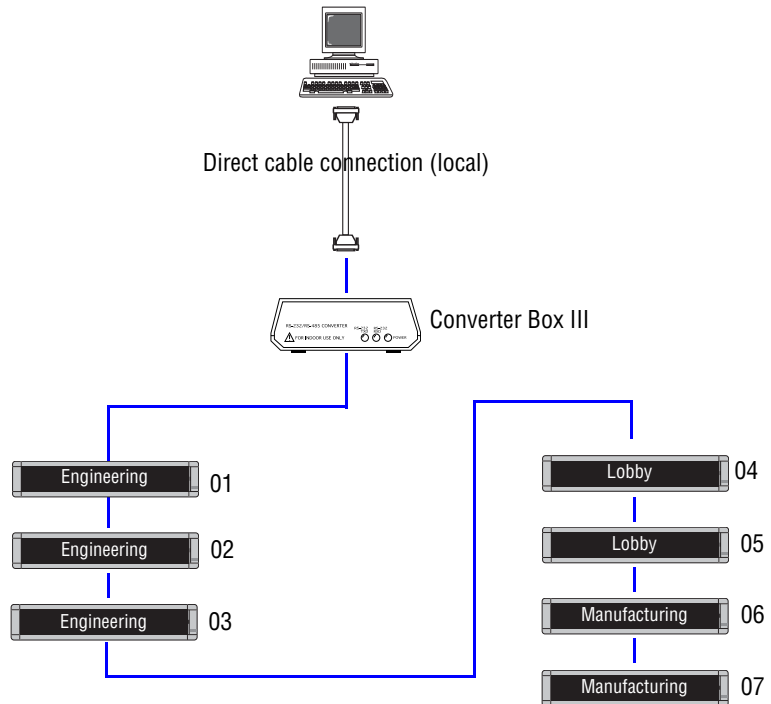

- Continuing from the previous step, select *Add* from the *Connection Device Editor* window. Then select *Local Wired Com 2* from the list, followed by *OK*:

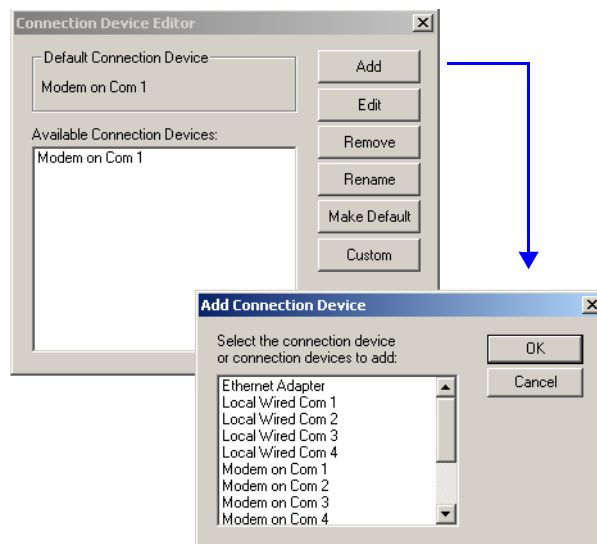

7. Once you select *OK*, the following window appears:

NOTE

To finish setting up a local connection, you have to create a local site using *Site Manager*.

To see an example of this, see “Creating the Lobby, Engineering, and Manufacturing sites — a wired example” on page 36.

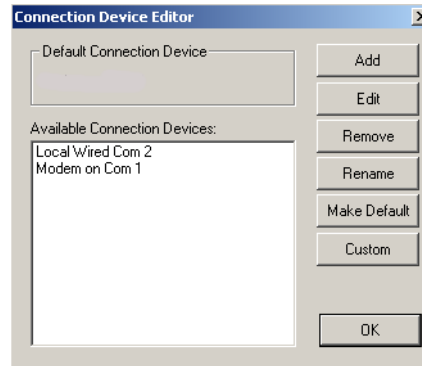

8. If you want to change any of the local settings, make sure *Local Wired Com 2* is highlighted as above and then select *Edit*. Use the following window to change the settings and then select *OK*:

Table 4: Local setup

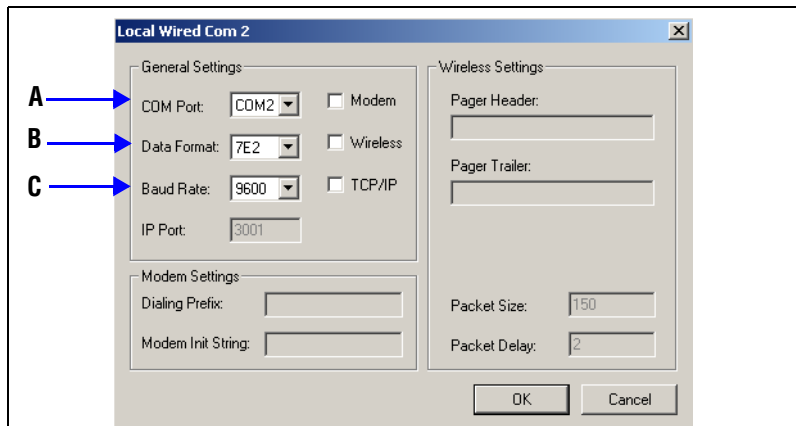

Item	Name	Directions
A	COM Port	Select the port on your PC that is cabled to your sign(s).
B	Data Format	Use <i>7E2</i> for 7 data bits, even parity, 2 stop bits. Use <i>8N1</i> for 8 data bits, no parity, 1 stop bit. (The <i>7E2</i> setting is compatible with most signs, but <i>8N1</i> must be used with an AlphaEclipse™ 3500 Series A sign.)
C	Baud Rate	Alpha® signs can receive at baud rates between 1200 and 9600 baud. Only AlphaPremiere™ and AlphaEclipse™ signs can use the 38400 baud setting.

BAUD RATE LIMIT

A Converter Box III with a serial number greater than AF00004525 (for example, AF00004526, AF00004527, and so on) has a minimum baud rate of 2400. Baud rates of 300 or 1200 will not be accepted, even though these rates are shown in *Connection Device Editor*.

Setting up a wireless transmitter connection

About Address 00

If you have multiple signs networked together, it's a good idea to give each sign a unique address, like *01*, *02*, *03*, and so on. This allows you to send messages to individual signs.

However, when you send a message to serial address 00, the message is broadcast to *all* signs on your network, even if each sign has a unique serial address.

To change a sign's address, see "Changing a sign's serial address" on page 16.

In our imaginary company, there is just one sign that uses a wireless connection. In this example, messages are sent to the sign using a wireless transmitter which is attached to a PC:

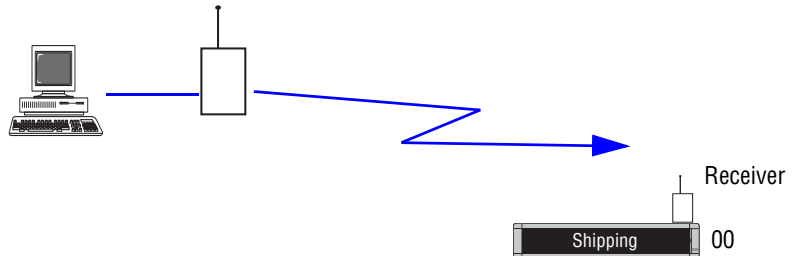

- Continuing from the previous step, select *Add* from the *Connection Device Editor* window. Select *WaveWare Pager Wireless Com 1* from the list, followed by *OK*:

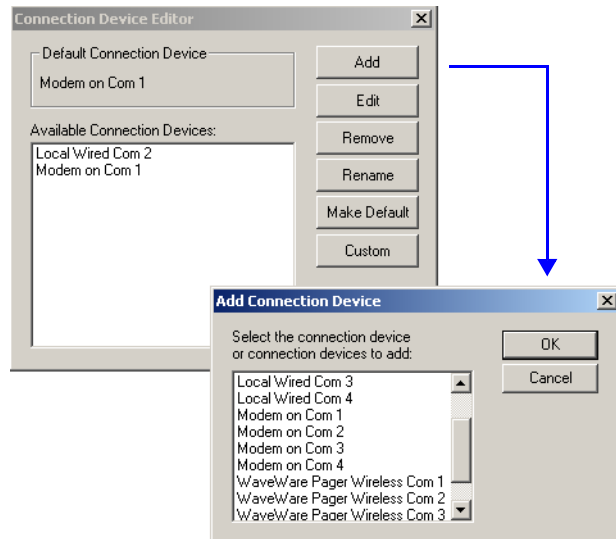

NOTE

Why can we choose *Wireless on COM1* when we already set up a *Modem on COM1*?

Site Manager assumes that you might have an AB switch attached to both a modem and a wireless transmitter. Or perhaps you unplug one device and plug in the other based on your needs.

- Once you select *OK*, the following window appears:

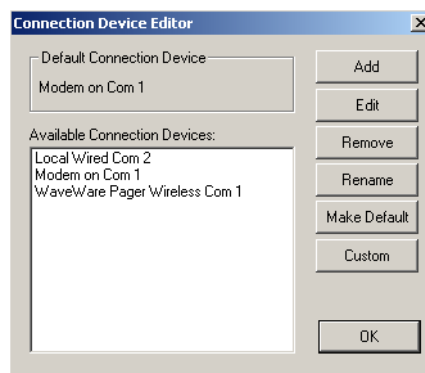

NOTE

To finish establishing a wireless connection, you have to create a wireless site using *Site Manager*.

To see an example of this, see "Creating the Shipping site — a wireless example" on page 40.

- 11.** If you want to change any of the wireless settings, make sure *WaveWare Pager Wireless Com 1* is highlighted as above and then select *Edit*. Use the following window to change the settings and then select *OK*.

Table 5: Wireless setup

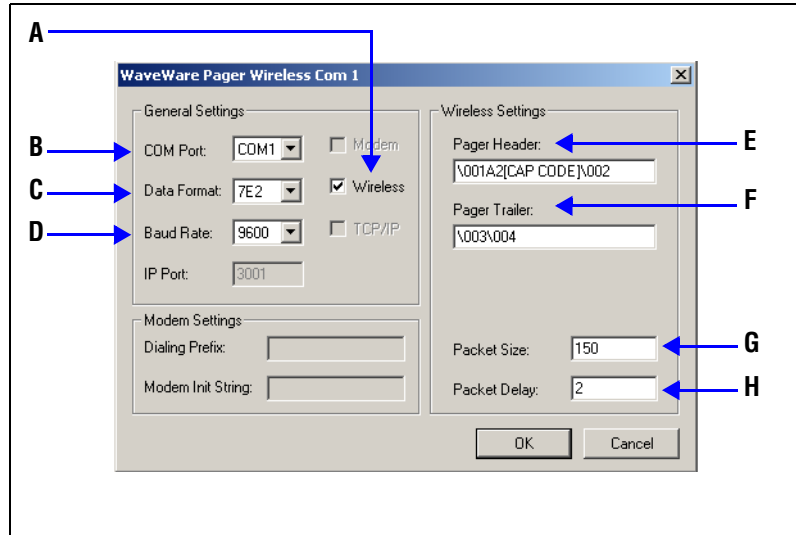

Item	Name	Directions
A	Modem	Do not check for a wireless connection.
	Wireless	Check <i>Wireless</i> if you are sending messages to signs using a transmitter attached to your PC.
B	COM Port	Select the port on your PC that connects to your modem or transmitter.
C	Data Format	Use <i>7E2</i> for 7 data bits, even parity, 2 stop bits. Use <i>8N1</i> for 8 data bits, no parity, 1 stop bit. (The <i>7E2</i> setting is compatible with most signs.)
D	Baud Rate	Alpha® signs can receive at baud rates between 1200 and 9600 baud. Only AlphaPremiere™ signs can use the 38400 baud setting.
E	Pager Header	Use these for your specific transmitter. Consult your transmitter documentation for details.
F	Pager Trailer	
G	Packet Size	
H	Packet Delay	

BAUD RATE LIMIT

A Converter Box III with a serial number greater than AF00004525 (for example, AF00004526, AF00004527, and so on.) has a minimum baud rate of 2400. Baud rates of 300 or 1200 will not be accepted, even though these rates are shown in *Connection Device Editor*.

Setting up a Local Area Network (LAN) connection

NOTE
For more detailed information, see the **Networking Alpha Signs** manual (pn 97000112).

In our imaginary company, there are two signs that use a LAN connection. In this example, messages are sent to these signs using an Alpha® Ethernet Adapter, which is connected to a LAN:

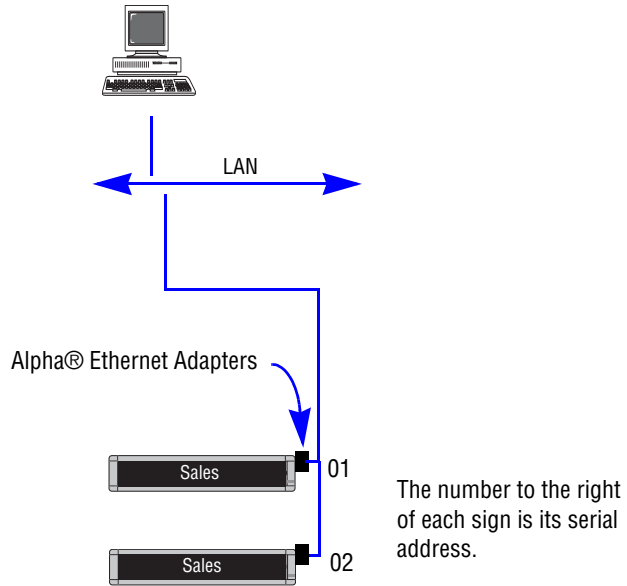

12. Continuing from the previous step, select *Add* from the *Connection Device Editor* window. Then select *Ethernet Adapter* from the list, followed by *OK*:

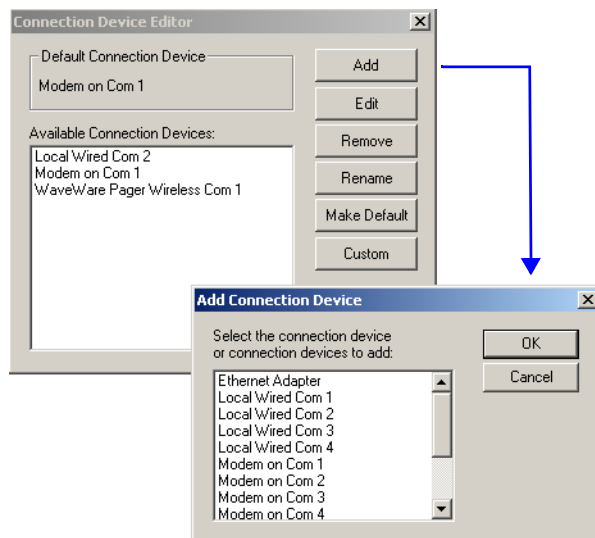

13. Once you select *OK*, the following window appears:

NOTE
 To finish setting up an Alpha® Ethernet Adapter connection, create a site using *Site Manager*.

 To see an example of this, see “Creating the Sales site — a LAN example” on page 33.

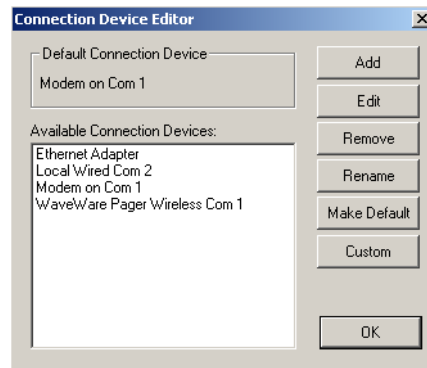

14. If you want to change any of the Alpha® Ethernet Adapter settings, make sure *Ethernet Adapter* is highlighted as above and then select *Edit*. Use the following window to change the settings, and then select *OK*:

Table 6: Alpha® Ethernet Adapter setup

Item	Name	Directions
A	TCP/IP	This must be checked.
B	IP Port	The default setting is 3001 for Alpha® Ethernet Adapters.

15. Finally, choose one of the devices as a default and then select *Make Default*. Select *Yes* at the prompt. Then, since we are finished adding devices in this example, select *OK*.

Before selecting *OK*, choose one of these devices and then select *Make Default*.

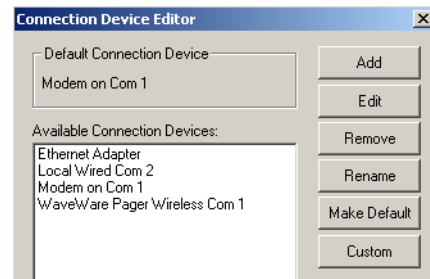

Step 2: Creating or changing the sites

Before creating the sites, there must be a device for each site. Since we did this in step 1, we can continue.

These are the sites we have to make for our imaginary company. Notice that many of them are just departments within the company. Sites/signs typically are named by location:

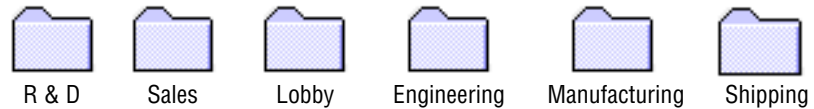

Creating the R & D site — a modem example

1. There are two signs in the R & D site (see “Schematic of the tutorial company” on page 18). One of these signs must be given an address of 01 and the other sign an address of 02 (see “How to change a sign’s serial address” on page 15).
2. To create the R & D site, open *Site Manager* if it is not already opened:

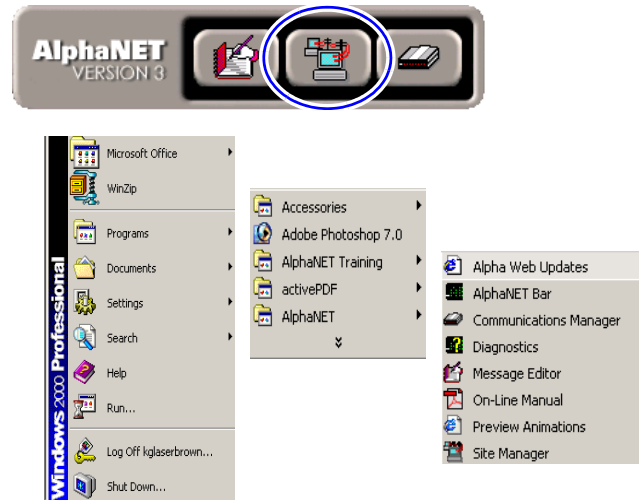

3. Select *File>New Site*:

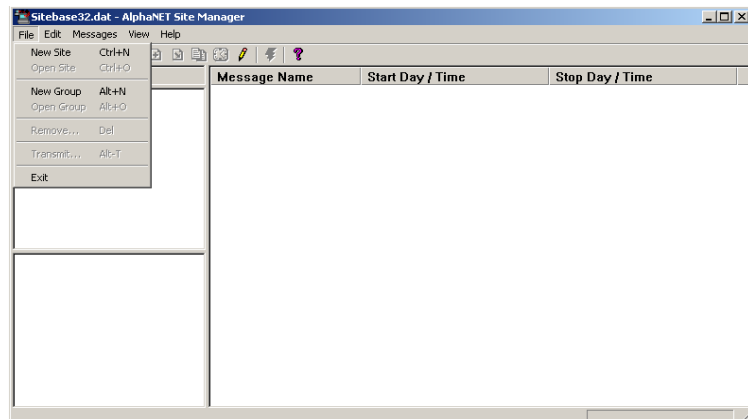

4. After selecting *New Site*, the *Site Editor* window appears:

Table 7: R & D setup (1 of 4): Site Editor (Site Info) window

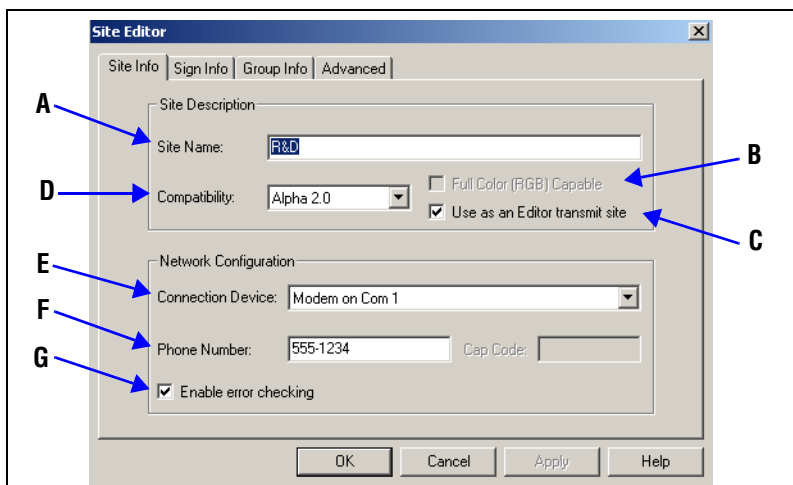

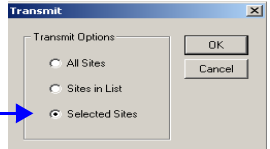
Item	Name	Directions
A	Site Name	Type <i>R & D</i> .
B	Full Color [RGB] Capable	Check this box when using an AlphaEclipse™ PureColor™ 3600 Series display sign (full color, not monochrome). Also, select <i>Alpha 3.0</i> under <i>Compatibility</i> .
C	Use as an Editor transmit site	When this is checked, the signs in the current site (in this case, the two R & D signs) receive messages sent from <i>Message Editor</i> . For example, if a message is sent from <i>Message Editor</i> with <i>Selected Sites</i> chosen (see below), then both the R & D signs receive that message.  Select this in <i>Message Editor</i> . This option is useful when you are testing to see what a message looks like before sending it to many signs.
D	Compatibility	<ul style="list-style-type: none"> • <i>Alpha 1.0 (EZ95)</i> — If all of your signs use the EZ95 protocol. • <i>EZ KEY II</i> — For the EZII protocol or Infrared Loader. • <i>Incandescent</i> — If all the signs on this site are either a 790i, 430i, 440i, or 460i. • <i>Alpha 2.0</i> — Includes features for the AlphaPremiere™ and AlphaEclipse™ series signs. • <i>Alpha 3.0</i> — Includes features for the AlphaEclipse™ PureColor™ 3600 Series sign.
E	Connection Device	Because both R & D signs are connected by a modem, select <i>Modem on Com 1</i> .
F	Phone Number	Enter the phone number the PC modem should dial. Include '9' to dial out, if necessary.
F	Enable error checking	Check for the software to verify that a sign received messages sent to it. When this option is on, errors will be recorded in the error log of <i>Communications Manager</i> .

NOTE

Be careful when you check *Use as an Editor transmit site* for more than one site.

Whenever you transmit *To Selected Sites* in *Message Editor*, the message will go to all sites designated as a transmit site.

This means you may have messages going to signs you did not intend to use.

NOTE

If you have signs networked together that use both the *Alpha 1.0* and *Alpha 2.0* protocols, select *Alpha 2.0*.

Also, if a site includes signs which use different protocols, some of the AlphaNET™ 3.0 software features may not work. Different sites should be created for signs with different protocols.

5. Next, enter information on the *Sign Info* tab:

Table 8: R & D setup (2 of 4): Site Editor (Sign Info) window

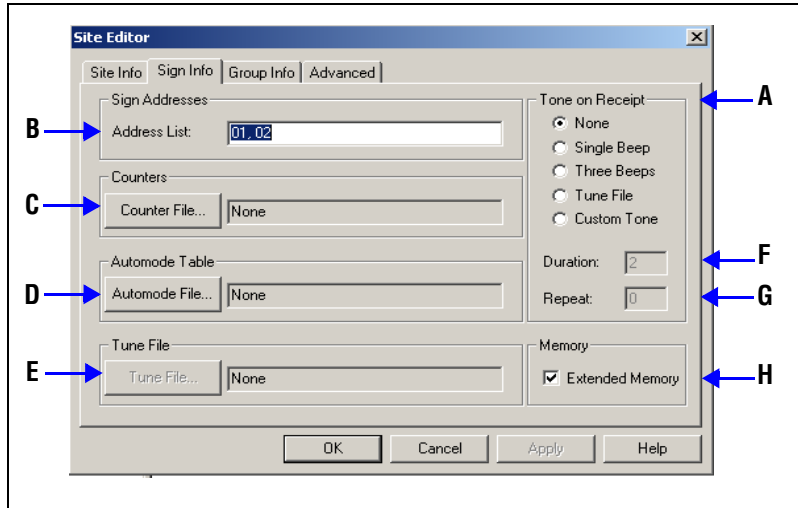

HINT

A long sequence of sign addresses can be entered using a comma.

For example, the address list: 5,6,7,8,9 could also be entered as 5-9.

Item	Name	Directions
A	Tone on Receipt	<ul style="list-style-type: none"> Select <i>Single Beep</i>, <i>Three Beeps</i>, or <i>Custom Tone</i> (create your own tone) if you want the signs in the address list to beep each time these signs receive a new message. Select <i>Tune File</i> if you want the signs in the address list to play a short melody each time these signs receive a new message. Only available on an AlphaPremiere™ 9000 sign.
B	Address List	<p>The addresses of all the signs in this particular site (in this case, 01 and 02 for the R & D site):</p> <div style="display: flex; align-items: center;"> <div style="border: 1px solid black; padding: 2px; margin-right: 5px;">R & D</div> <div style="margin-right: 10px;">01</div> <div style="border-left: 1px solid black; height: 20px; margin: 0 5px;"></div> <div style="margin-right: 10px;">02</div> </div> <p>Addresses of R & D signs (See NOTE at the end of this example.)</p>
C	Counter File...	See "How to edit a counter file" on page 81.
D	Automode File...	<p>Choose an automode table, if desired. (<i>Compatibility</i> on the <i>Site Info</i> tab must be <i>Alpha 2.0</i> or <i>Alpha 3.0</i> for <i>Automode Table...</i> to be available.)</p> <p>See "How to create and use a custom automode sequence" on page 107 for more information.</p>
E	Tune File	Signs in the address list can play a tune file each time they receive a message. To do this, select <i>Tone on Receipt</i> > <i>Tune File</i> . Then browse and select one of the pre-programmed tune files. Only available on an AlphaPremiere™ 9000 sign.
F	Duration	In seconds, the length of time each beep will sound.
G	Repeat	The number of times the beep (or series of beeps) will sound.
H	Extended Memory	Used for large file transmissions, such as when sending graphics to a display sign. Must be selected when sending to an AlphaPremiere™ 9000 or AlphaEclipse™ sign.

6. In this example, nothing needs to be changed on the *Group Info* tab:

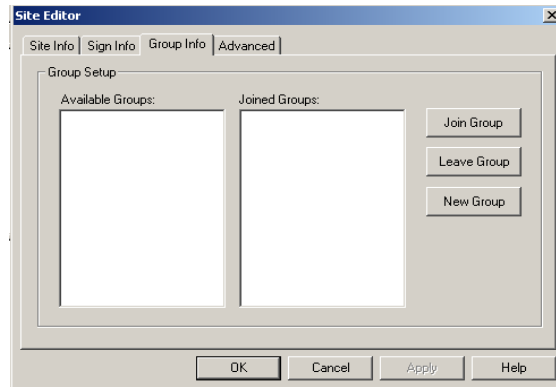

7. In this example, nothing needs to be changed on the *Advanced* tab:

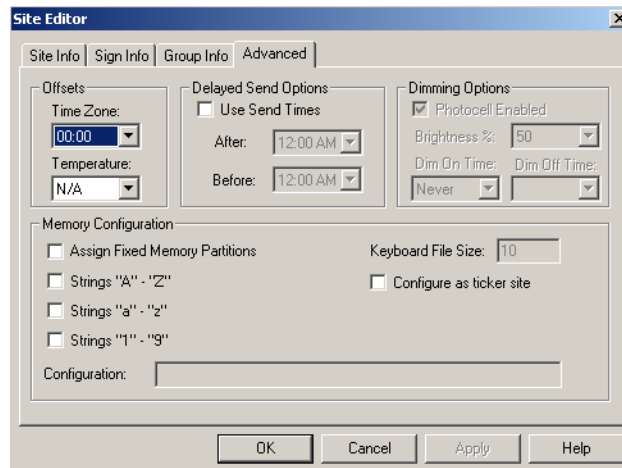

8. Select *OK* and the following appears:

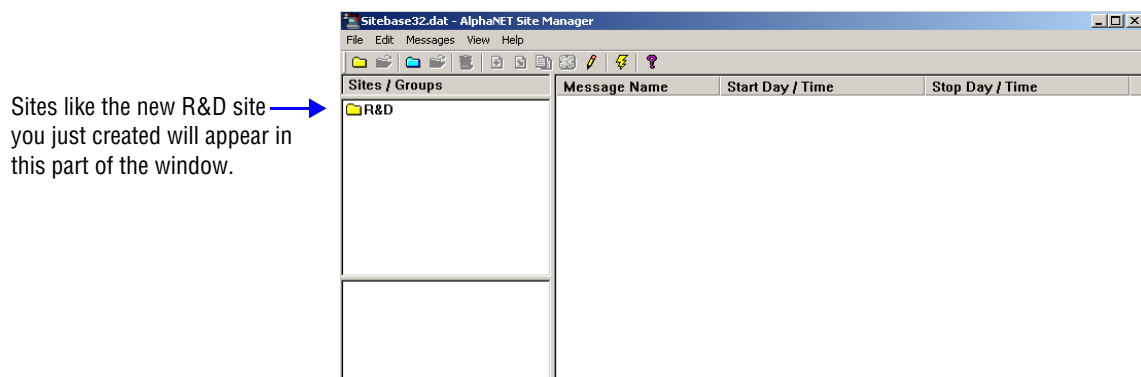

Creating the Sales site — a LAN example

9. After making the R & D site, we'll create the Sales site, which consists of two signs (see "Schematic of the tutorial company" on page 18). First, select *File>New Site*:

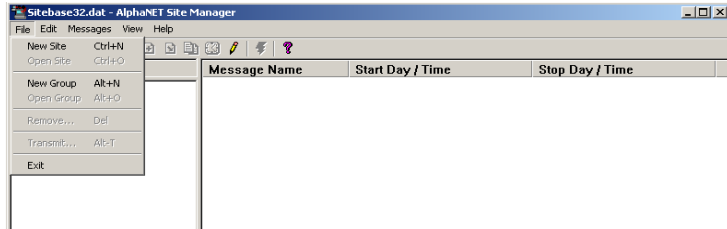

10. After selecting *New Site*, the *Site Editor* window appears:

Table 9: Sales setup (1 of 4): Site Editor (Site Info) window

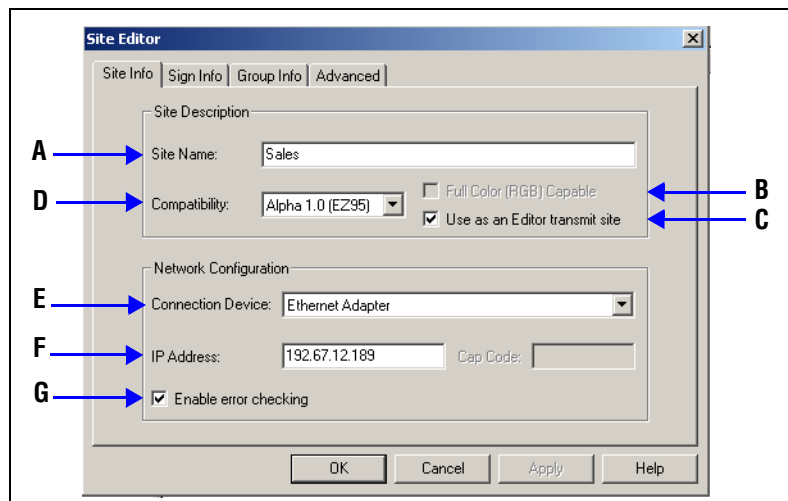

Item	Name	Directions
A	Site Name	Type <i>Sales</i> .
B	Full Color [RGB] Capable	Check this box when using an AlphaEclipse™ PureColor™ 3600 Series display sign (full color, not monochrome.) Also, select <i>Alpha 3.0</i> under <i>Compatibility</i> .
C	Use as an Editor transmit site	See "R & D setup (1 of 4): Site Editor (Site Info) window" on page 30.
D	Compatibility	
E	Connection Device	Because the Sales sign is connected by an Alpha® Ethernet Adapter, select <i>Ethernet Adapter</i> .
F	IP Address	Specify the 4-node Internet Protocol address for this sign. See your network administrator if you do not know this address. See the Networking Alpha® Signs manual (pn 97000112) for information about assigning an address to an ethernet adapter.
G	Enable error checking	Check this if you want the software to verify that a sign received messages sent to it. When this option is on, errors will be recorded in the error log of <i>Communications Manager</i> .

11. Next, enter information on the *Sign Info* tab:

Table 10: Sales setup (2 of 4): Site Editor (Sign Info) window

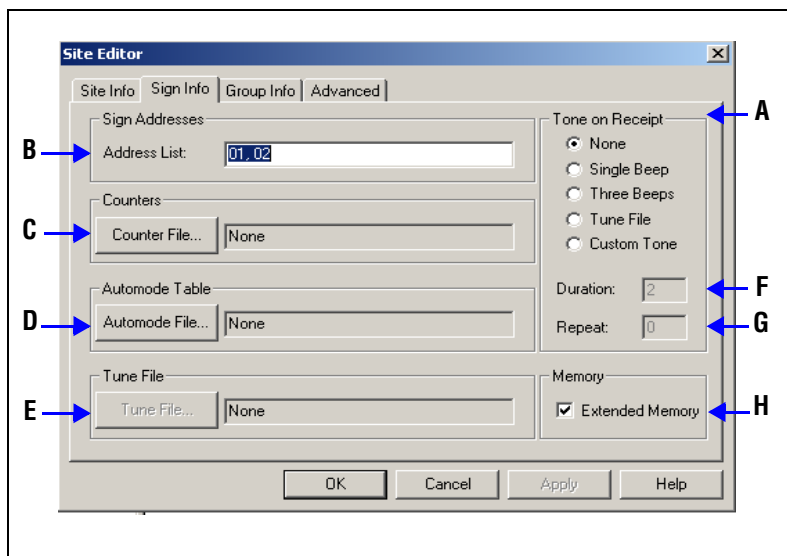

HINT

A long sequence of sign addresses can be entered using a hyphen.

For example, the address list: 5,6,7,8,9 could also be entered as 5-9.

Item	Name	Directions
A	Tone on Receipt	See “R & D setup (2 of 4): Site Editor (Sign Info) window” on page 31.
B	Address List	The addresses of the Sales signs are 01 and 02. 
C	Counter File...	See “How to edit a counter file” on page 81.
D	Automode File...	Choose an automode table, if desired. (<i>Compatibility</i> on the <i>Site Info</i> tab must be <i>Alpha 2.0</i> or <i>Alpha 3.0</i> for <i>Automode Table...</i> to be available.) See “How to create and use a custom automode sequence” on page 107 for more information.
E	Tune File	Signs in the address list can play a tune file each time they receive a message. To do this, select <i>Tone on Receipt > Tune File</i> . Then browse and select one of the pre-programmed tune files. Only available on an AlphaPremiere™ 9000 sign.
F	Duration	In seconds, the length of time each beep will sound.
G	Repeat	The number of times the beep (or series of beeps) will sound.
H	Extended Memory	Used for large file transmissions, such as when sending graphics to a display sign. Must be selected when sending to an AlphaPremiere™ 9000 or AlphaEclipse™ sign.

12. In this example, nothing needs to be changed on the *Group Info* tab:

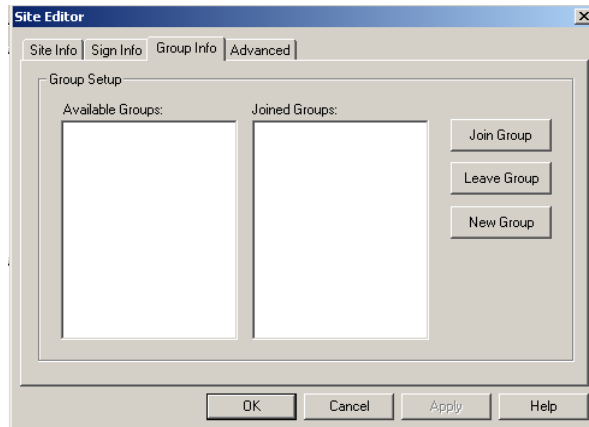

13. In this example, nothing needs to be changed on the *Advanced* tab:

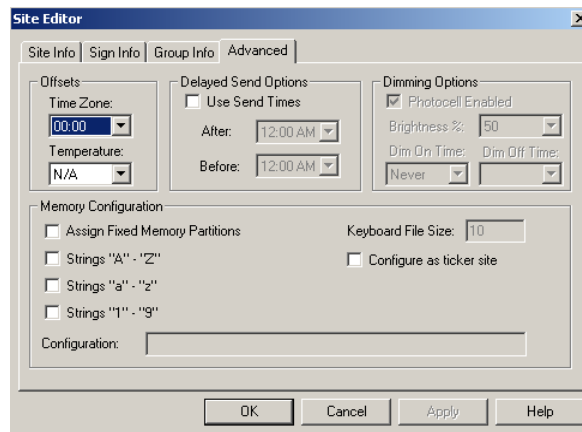

14. Select *OK* and the following appears:

The new Sales site will appear in this part of the window along with the R & D site.

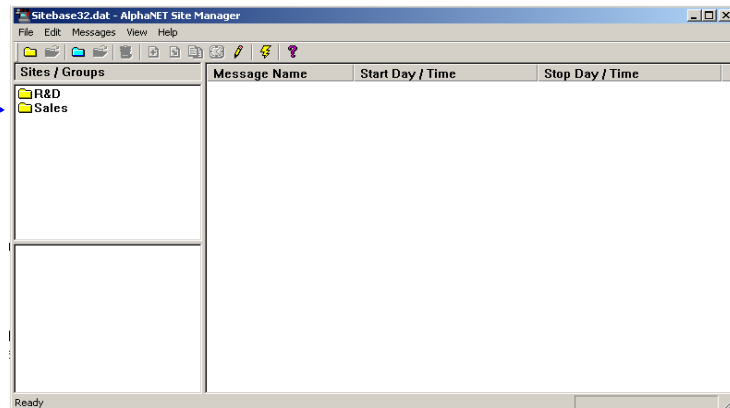

Creating the Lobby, Engineering, and Manufacturing sites — a wired example

- 15.** After creating the Sales site, we'll create the Local sites. First, we'll create the two lobby signs. Select *File>New Site*:

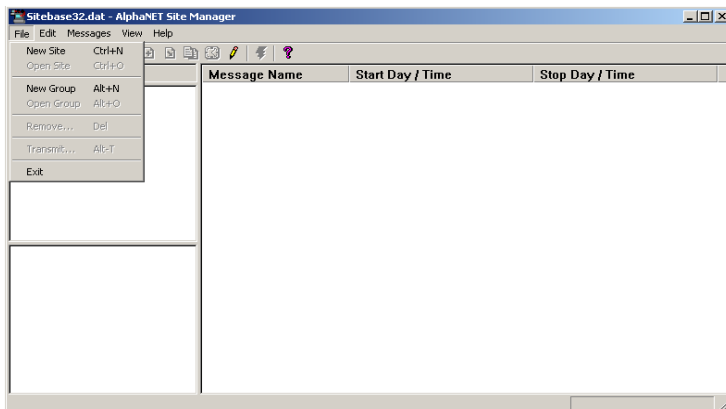

- 16.** After selecting *New Site*, the *Site Editor* window appears:

Table 11: Lobby setup (1 of 4): Site Editor (Site Info) window

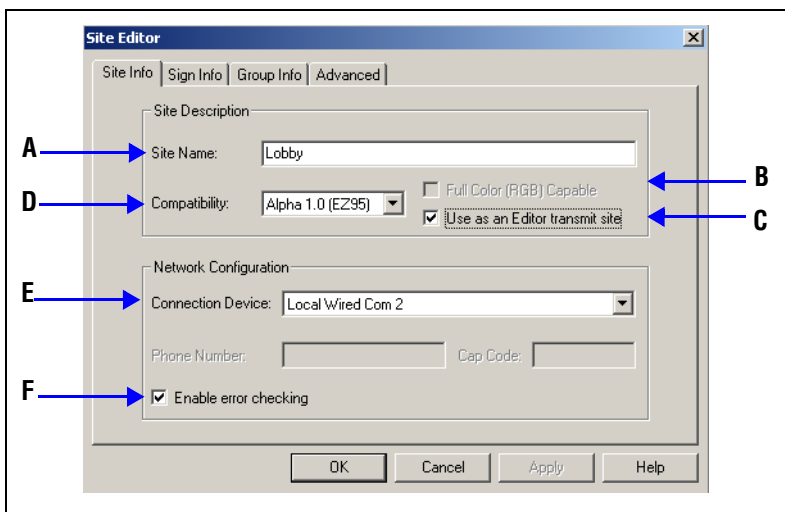

Item	Name	Directions
A	Site Name	Type <i>Lobby</i> .
B	Full Color [RGB] Capable	Check this box when using an AlphaEclipse™ PureColor™ 3600 Series display sign (full color, not monochrome). Also, select <i>Alpha 3.0</i> under <i>Compatibility</i> .
C	Use as an Editor transmit site	See "Sales setup (1 of 4): Site Editor (Site Info) window" on page 33.
D	Compatibility	
E	Connection Device	
F	Enable error checking	

17. Next, enter information on the *Sign Info* tab:

Table 12: Lobby setup (2 of 4): Site Editor (Sign Info) window

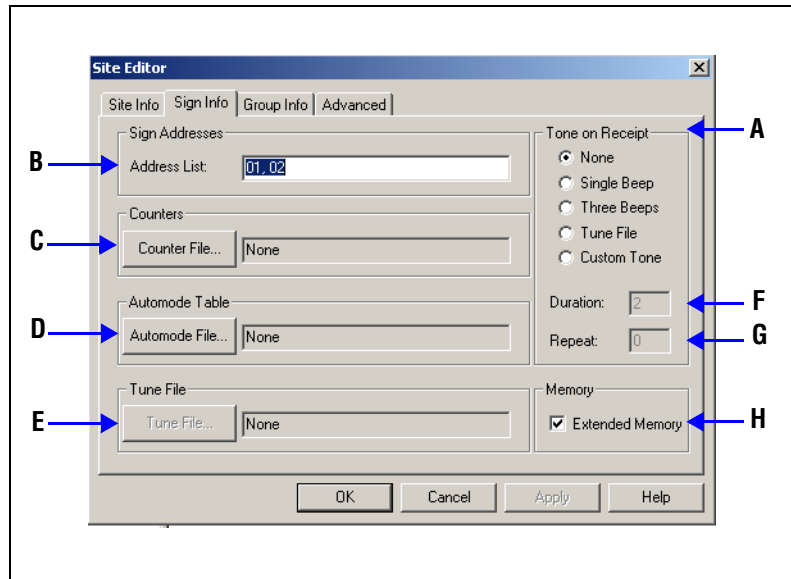

HINT

A long sequence of sign addresses can be entered using a hyphen.

For example, the address list: 5,6,7,8,9 could also be entered as 5-9.

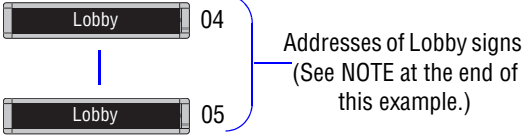
Item	Name	Directions
A	Tone on Receipt	See "Sales setup (2 of 4): Site Editor (Sign Info) window" on page 34.
B	Address List	Change the addresses of the Lobby signs to 04 and 05: 
C	Counter File...	See "How to edit a counter file" on page 81.
D	Automode File...	Choose an automode table, if desired. (<i>Compatibility</i> on the <i>Site Info</i> tab must be <i>Alpha 2.0</i> or <i>Alpha 3.0</i> for <i>Automode Table...</i> to be available.) See "How to create and use a custom automode sequence" on page 107 for more information.
E	Tune File	Signs in the address list can play a tune file each time they receive a message. To do this, select <i>Tone on Receipt > Tune File</i> . Then browse and select one of the pre-programmed tune files. Only available on an AlphaPremiere™ 9000 sign.
F	Duration	In seconds, the length of time each beep will sound.
G	Repeat	The number of times the beep (or series of beeps) will sound.
H	Extended Memory	Used for large file transmissions, such as when sending graphics to a display sign. Must be selected when sending to an AlphaPremiere™ 9000 or AlphaEclipse™ signs.

18. In this example, nothing needs to be changed on the *Group Info* tab:

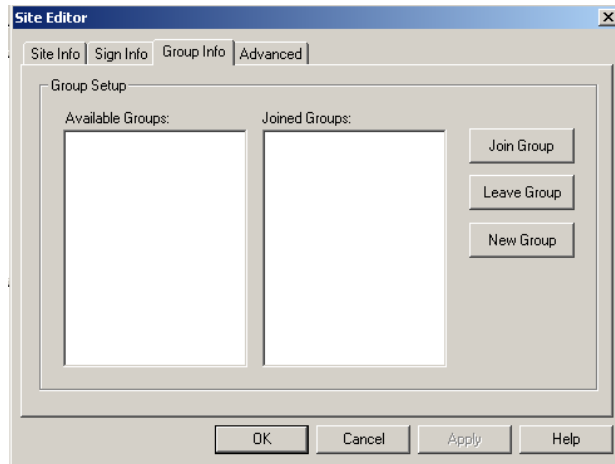

19. In this example, nothing needs to be changed on the *Advanced* tab:

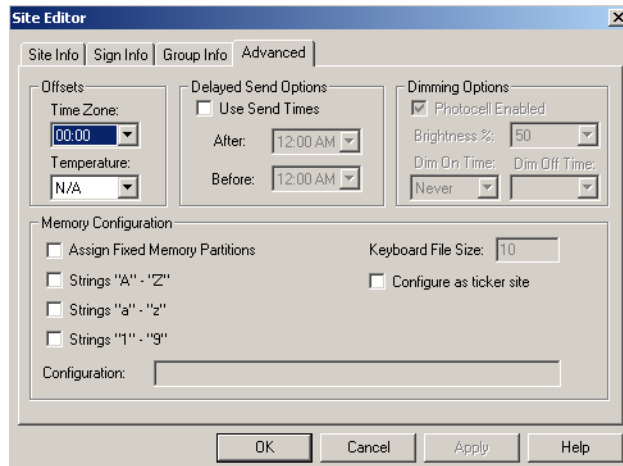

20. Select *OK* and the following appears:

The new Lobby site will appear in this part of the window along with the other sites you created. →

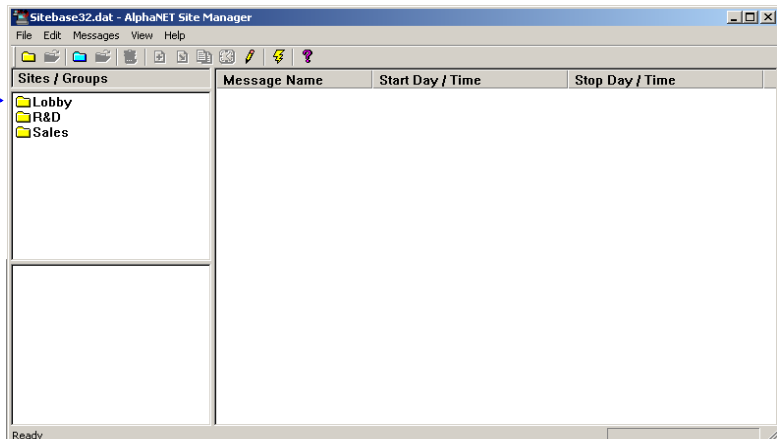

21. The Engineering and Manufacturing sites are created just like the Lobby site. However, make sure that addresses of the Engineering and Manufacturing signs are set as follows:

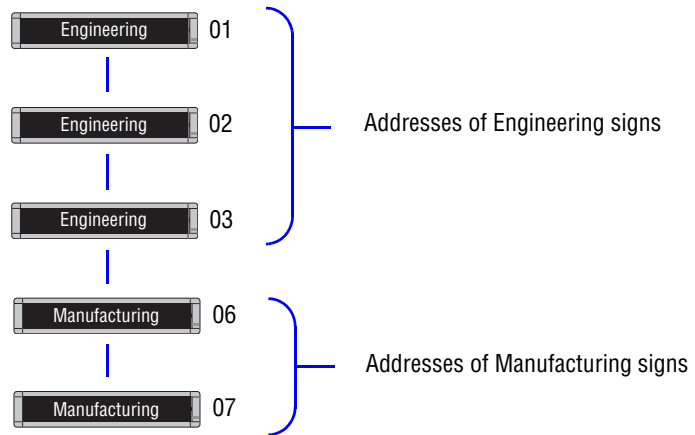

Note: To set the address of a sign see “How to change a sign’s serial address” on page 15.

Creating the Shipping site — a wireless example

22. The last site we have to create is Shipping, which is a wireless site. Select *File>New Site*:

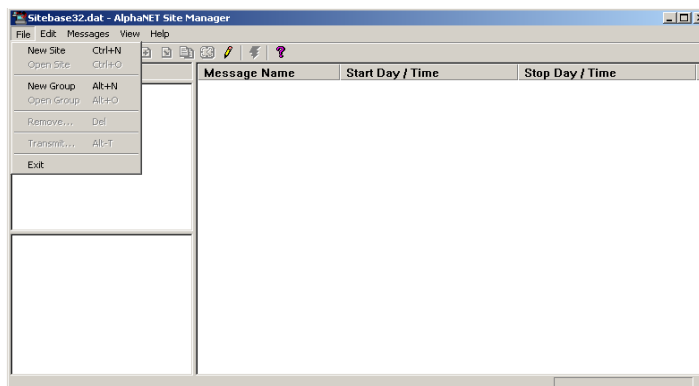

23. After selecting *New Site*, the *Site Editor* window appears:

Table 13: Shipping setup (1 of 4): Site Editor (Site Info) window

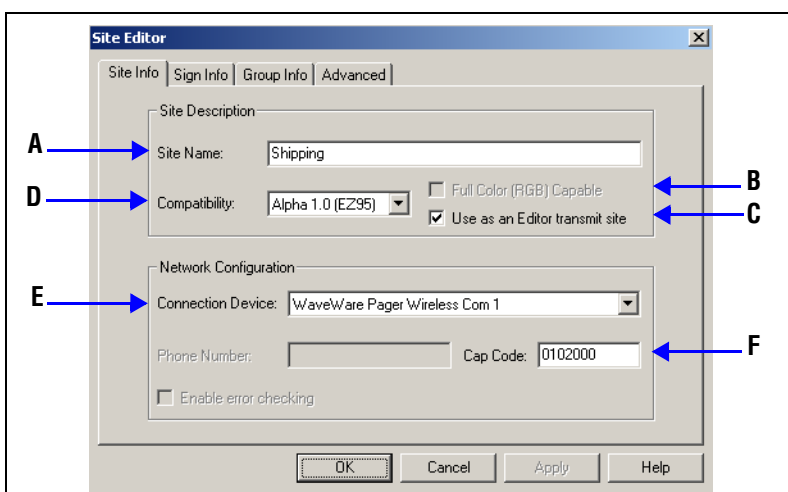

Item	Name	Directions
A	Site Name	Type <i>Shipping</i> .
B	Full Color [RGB] Capability	Check this box when using an AlphaEclipse™ PureColor™ 3600 Series display sign (full color, not monochrome). Also, select <i>Alpha 3.0</i> under <i>Compatibility</i> .
C	Use as an Editor transmit site	See “Sales setup (1 of 4): Site Editor (Site Info) window” on page 33.
D	Compatibility	
E	Connection Device	Select <i>WaveWare Pager Wireless Com 1</i> . Note that with a wireless connection to an AlphaEclipse™ configured with transceivers, use a <i>Local Wired</i> connection device.
F	Cap Code	Complete this according to your specific pager/receiver. Consult your pager/receiver documentation for details.

24. Next, enter information on the *Sign Info* tab:

Table 14: Shipping setup (2 of 4): Site Editor (Sign Info) window

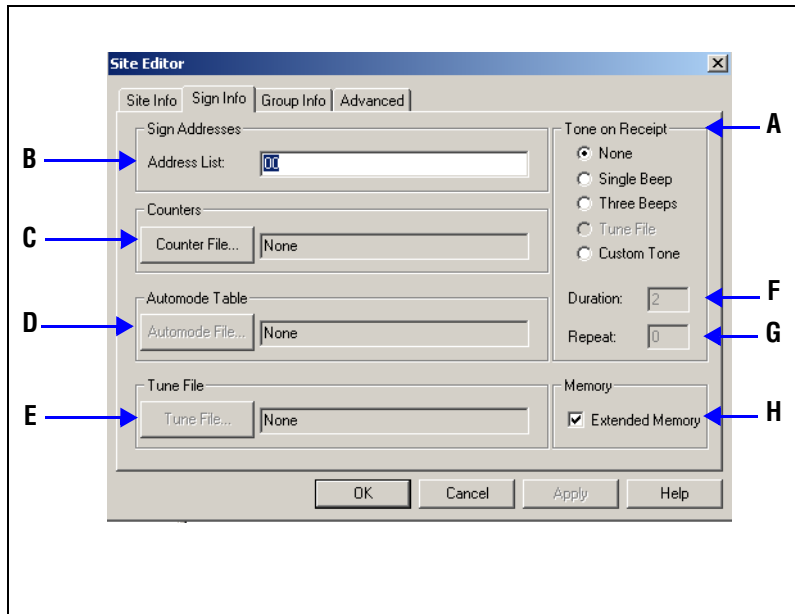

Item	Name	Directions
A	Tone on Receipt	See “Sales setup (2 of 4): Site Editor (Sign Info) window” on page 34.
B	Address List	The address of the Shipping sign can be left at its factory default value of 00. 
C	Counter File...	See “How to edit a counter file” on page 81.
D	Automode File...	Choose an automode table, if desired. (<i>Compatibility</i> on the <i>Site Info</i> tab must be <i>Alpha 2.0</i> or <i>Alpha 3.0</i> for <i>Automode Table...</i> to be available.) See “How to create and use a custom automode sequence” on page 107 for more information.
E	Tune File	Signs in the address list can play a tune file each time they receive a message. To do this, select <i>Tone on Receipt > Tune File</i> . Then browse and select one of the pre-programmed tune files. Only available on an AlphaPremiere™ 9000 sign.
F	Duration	In seconds, the length of time each beep will sound.
G	Repeat	The number of times the beep (or series of beeps) will sound.
H	Extended Memory	Used for large file transmissions, such as when sending graphics to a display sign. Must be selected when sending to an AlphaPremiere™ 9000 or AlphaEclipse™ sign.

25. In this example, nothing needs to be changed on the *Group Info* tab:

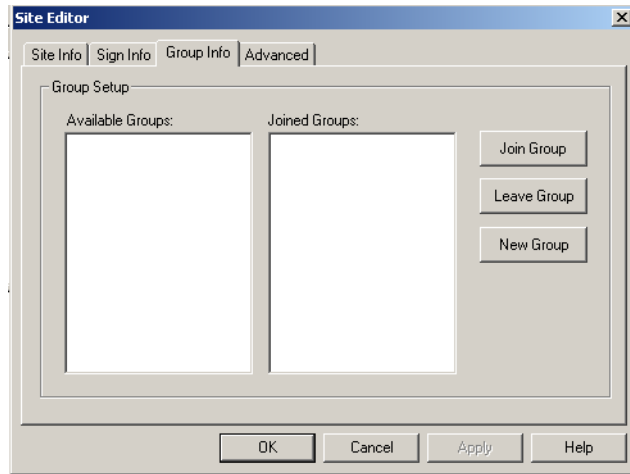

26. In this example, nothing needs to be changed on the *Advanced* tab:

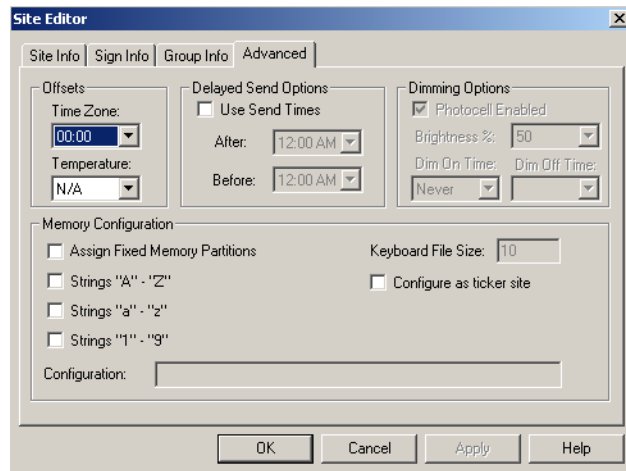

27. Select *OK* and the following appears:

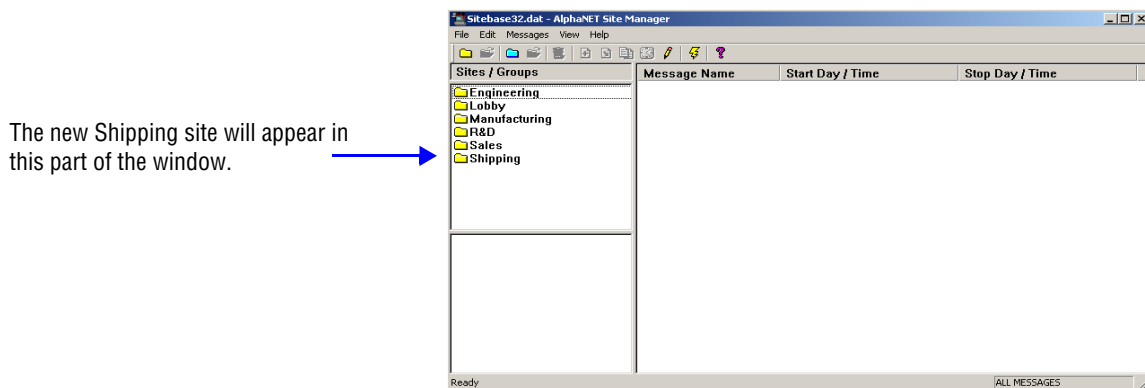

Step 3: Creating or changing the groups

A group is a collection of one or more sites. In our imaginary company, there are two groups, Administration and Production.

Groups are a convenient method of organizing sites into categories so that messages can easily be sent to multiple sites.

For example, in our imaginary company, we might have a message intended for just the R &D site or just the Sales and Lobby sites. However, many times we will want a message to go to the R &D and the Sales and the Lobby sites. This is where groups come in. A group is a method of sending messages to several sites.

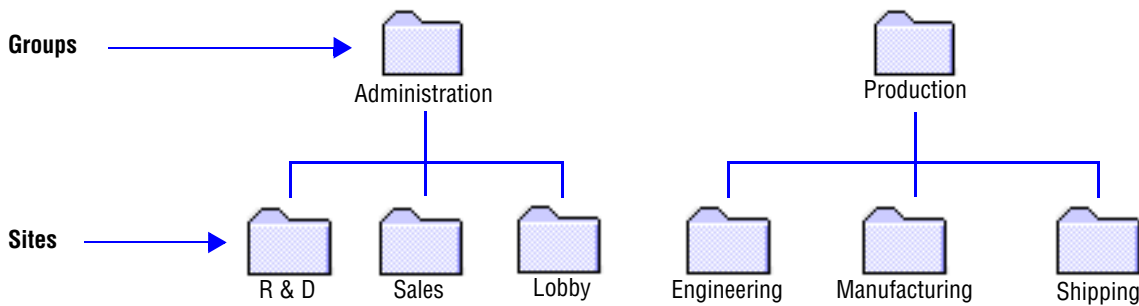

1. To create the Administration group, open *Site Manager* if it is not already opened:

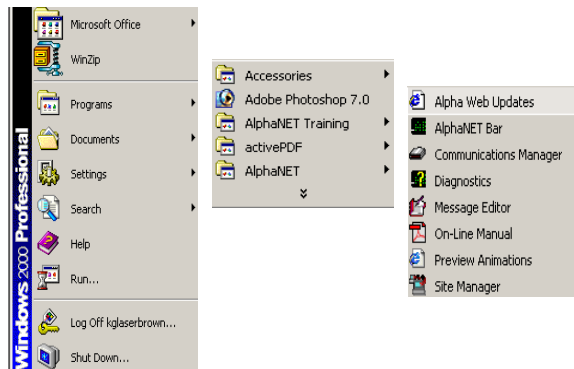

These are the sites created in the previous examples.

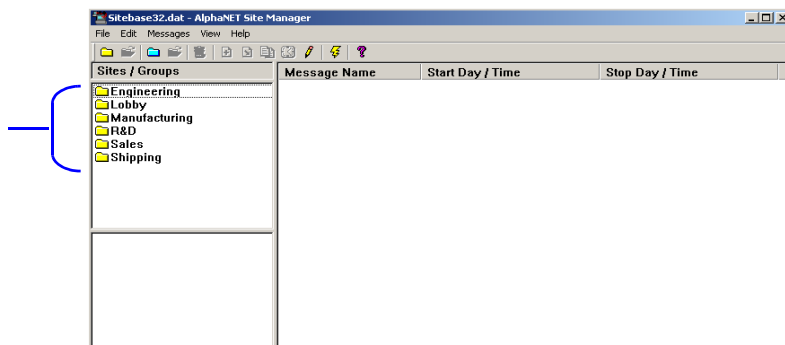

2. Select *File>New Group*. The following appears:

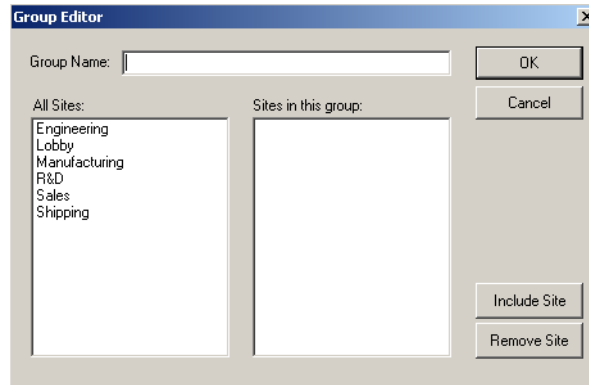

3. For *Group Name*, type *Administration*. Next, click *R & D* and then *Include Site* to add the R & D site to the Administration group. (You can also double-click the sites to include them.) Add the *Sales* and *Lobby* sites to the Administration group in the same way:

HINT
Use the *Ctrl* key to select multiple sites.

Also, you can double-click a site to include it. However, to exclude a site, you must select it in the right column and then click *Remove Site*.

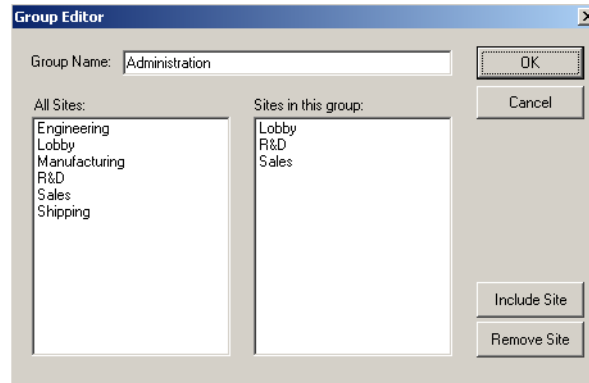

4. When you are finished adding the *Sales* and *Lobby* sites, select *OK* and the following appears:

Groups, like Administration, will appear in this area. →

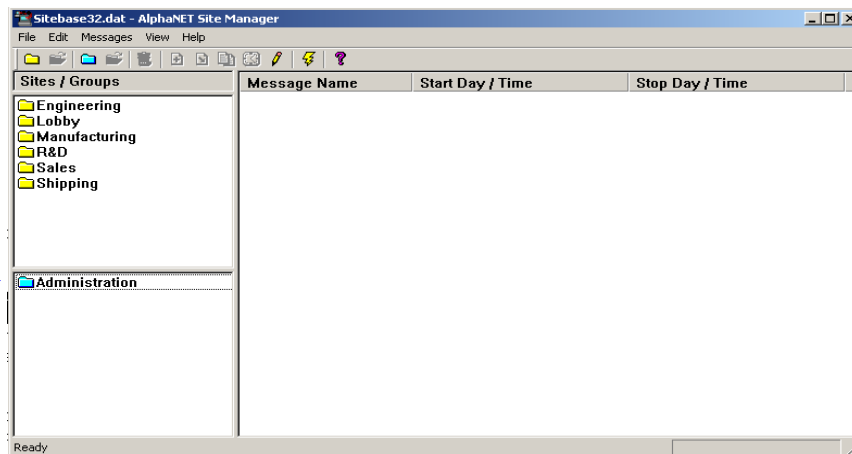

5. To see the sites that belong to a single group, just click on that group. The folder for the group will open and only the sites in that group will be listed:

NOTE
To return to seeing all sites, hold down the *Ctrl* key while clicking once on the name of the group you just chose in this step. The folder icon for that group will close and all other sites will be listed.

When you select a group, the sites in the group appear.

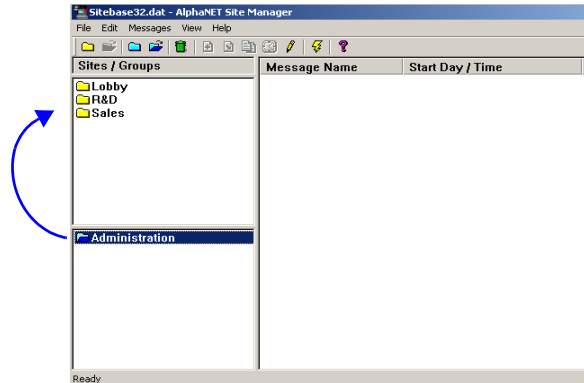

6. The Production group is created almost exactly like the Administration group. However, the Production group is made up of the Engineering, Manufacturing, and Shipping sites. After adding the Production group, this window appears:

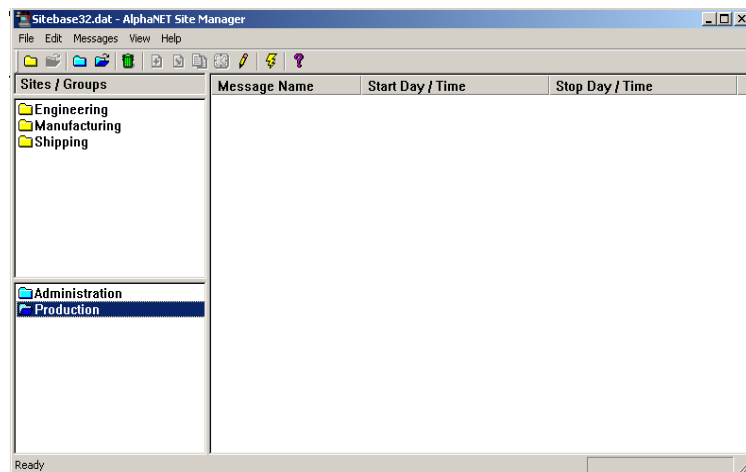

THIS PAGE INTENTIONALLY BLANK

3

Creating and sending messages

Basic message editing

Because AlphaNET™ 3.0 software allows you an infinite number of ways to create a message for a sign, it is not possible to show every one. In the following pages, however, examples of basic and advanced message editing are presented.

First, the basics.

Using Message Editor to create your message

1. After installing the AlphaNET™ 3.0 software on your PC, open *Message Editor*. Then open a window for a new message:

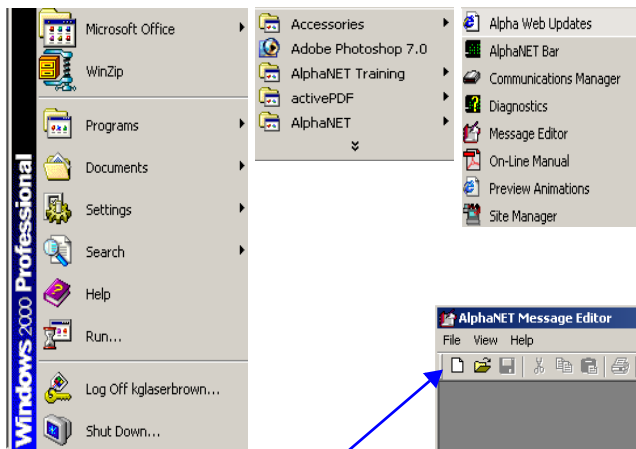

Select *Start>Programs>AlphaNET >Message Editor* or click the *Message Editor* button on the AlphaNET™ bar.



Then click  to create a new message window.

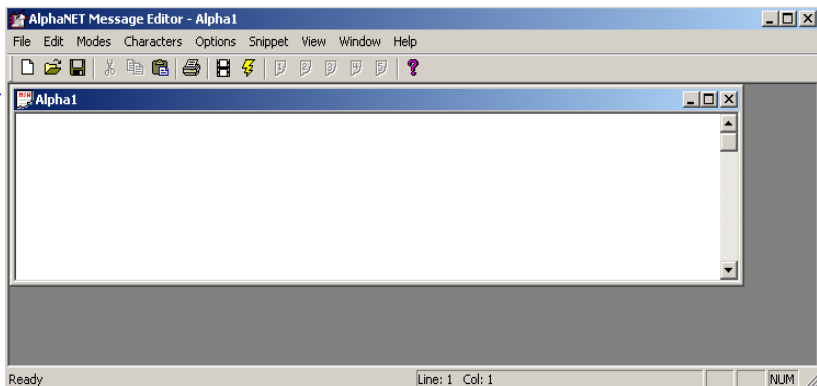
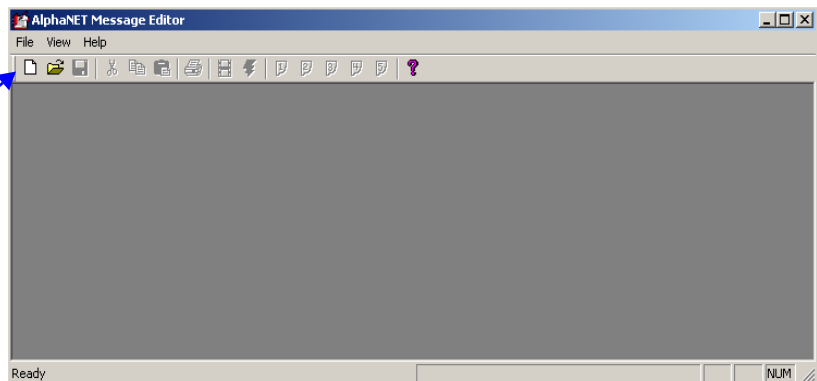

2. Type *The first message* in the window:

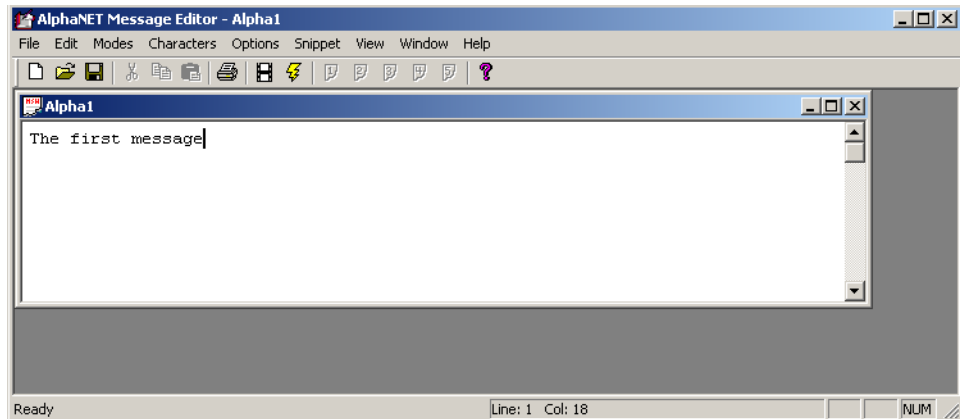

3. Use *File>Simulate* to view what the message will look like on a sign, or click the *Simulate* button on the toolbar:

Click here to view what your message will look like on a sign.

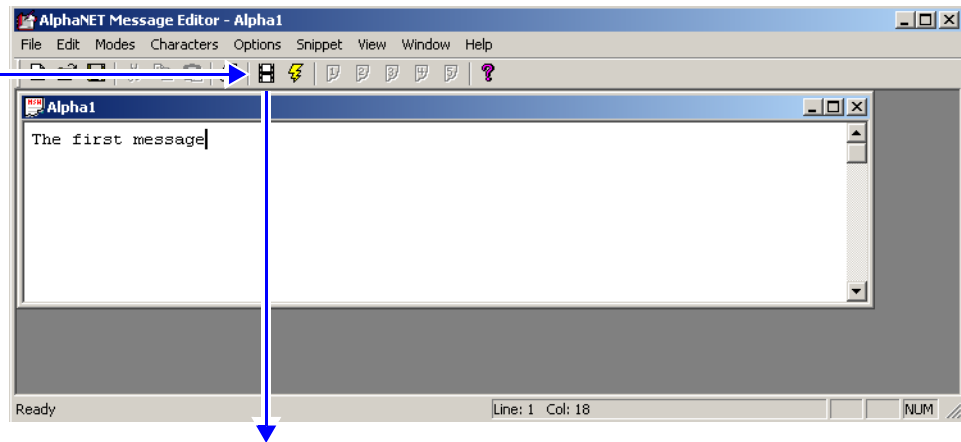

HINT

Right-click on the simulator and click *Change Display* to choose a different sign to emulate.

The type of display you select appears on the title bar.



Note:The type of sign on which your message is being simulated appears on the title bar of the window (in this case, an Alpha® 7120C). To change it, right-click anywhere on the simulated message and select *Change Display*.

4. Add the current date to your message. First, close the window in which your message is being simulated. Then select *Options>Date* in *Message Editor*:

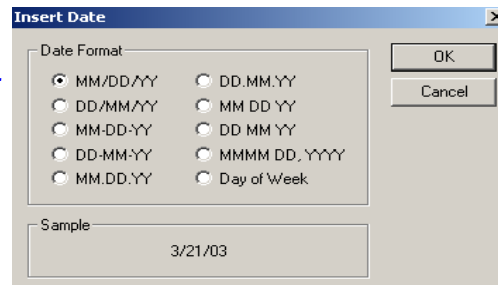
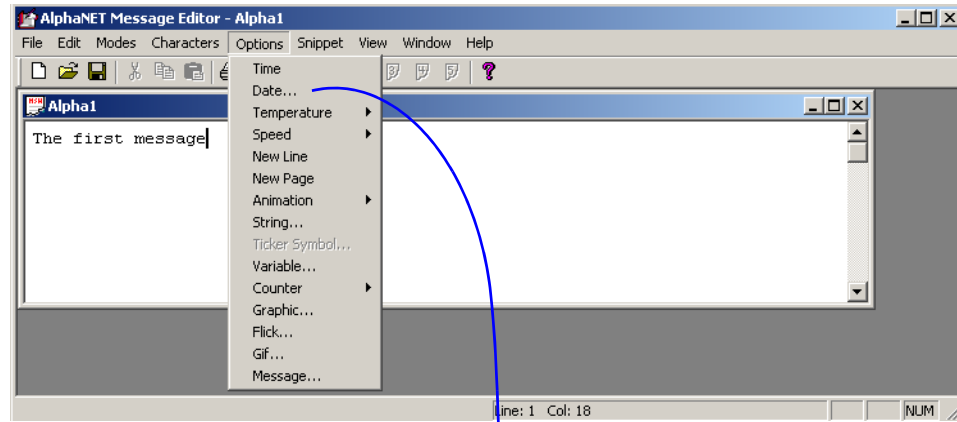

In the *Insert Date* window, select *OK* and a date icon will appear at the end of the message.

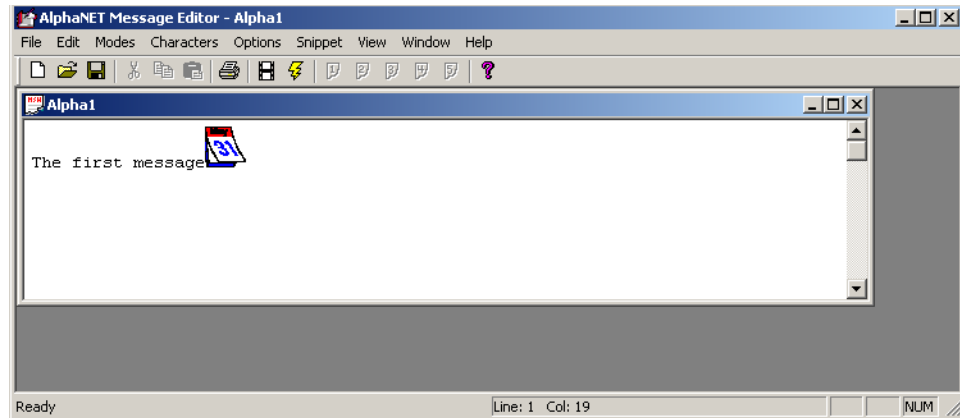

5. Then view your message again using the *Simulate* button:



Using modes to change the look of a message

Modes are special effects that change the way a message appears on a sign. For example, the *Rotate* mode moves a message from right to left across a sign. In this example, you will create a message that displays employee birthdays.

NOTE: Some modes are not available on some signs. For a list of what modes are available, see “Appendix B — Modes available on signs” on page 137.

Example 1: How to display employee birthdays.

In this example, the *Hold* and *Rotate* modes are used to display employee birthdays. This setup has a variety of uses, such as announcements and anniversaries.

In the *Hold* mode, the top line remains fixed while the names go by.

In the *Rotate* mode, the names move from right to left on the bottom line.



See “Appendix E — Understanding message line positions (Top, Middle, Bottom, Fill)” on page 141.

6. To create Example 1, close the previous message but don’t save it. Next, open a new message. Then select *Modes>Hold*:

HINT

Place the cursor over an icon and click the right mouse button to see a short description of the icon at the bottom of the *Message Editor* window. For example:



Click the right mouse button



Top Hold

You can also switch between using pictures and using text descriptions for the icons by selecting *Edit > Customize* and changing the icon style

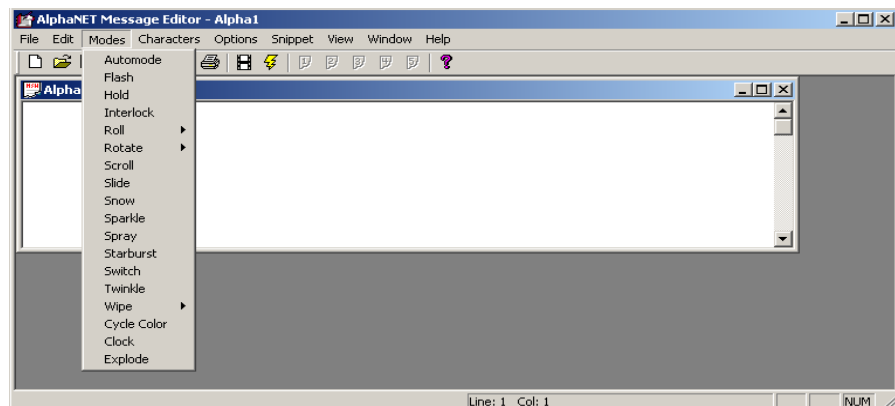

7. When the following window appears, select *Top* and then *OK*:

Line Position is where a message appears on a sign. See “Appendix E — Understanding message line positions (Top, Middle, Bottom, Fill)” on page 141 for more details.

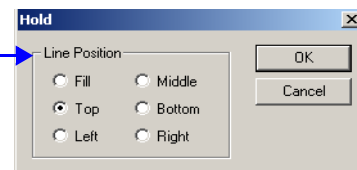

8. The icon for *Hold* will appear in the message window:

This little marker indicates that the text following this icon will appear on the top line of a display. →

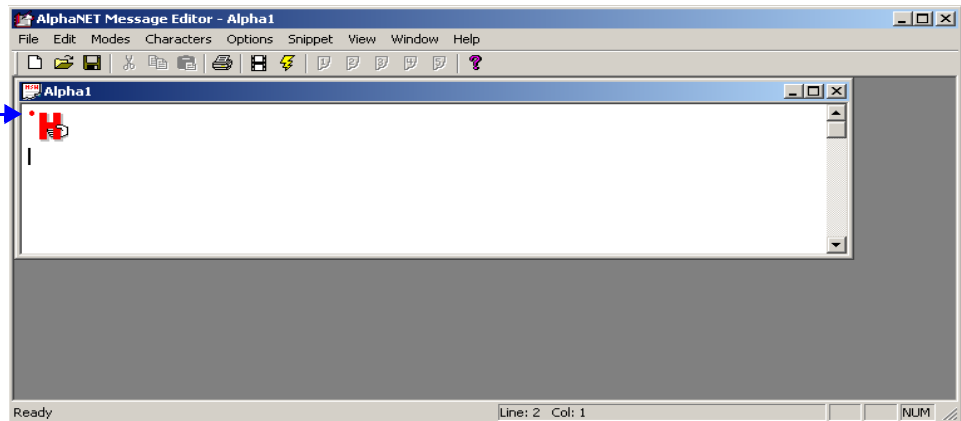

9. Type *Birthdays*. Then select *Modes>Rotate>Standard>Bottom*. Click *OK* and then type: *Tom White, Patty Smith, Bob Evan*.

Select *Rotate>Standard*

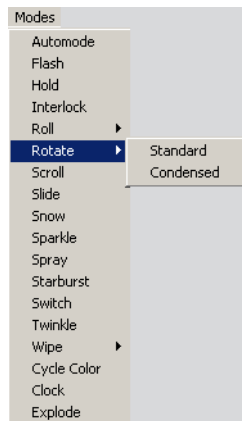

...and the *Bottom* line position.

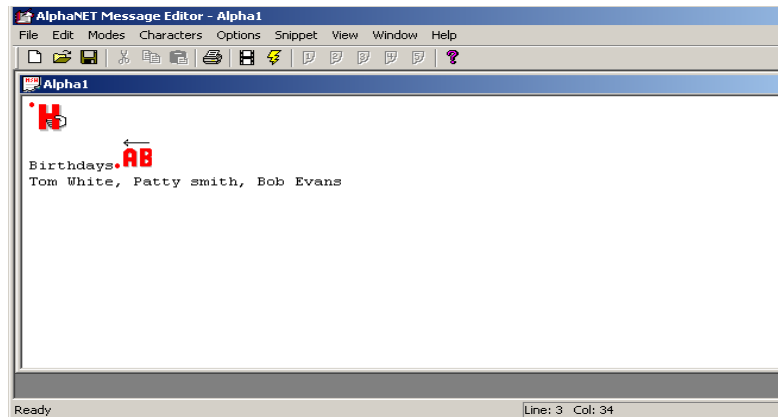
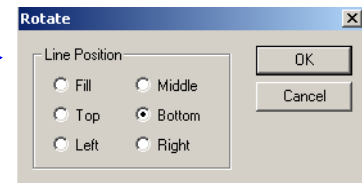

10. Next, click  to view your message:

HINT

View (simulate) your message to see exactly how it will appear on a sign.

You can see how fonts, colors, and graphics will appear on a sign and also how much text will appear on a line. (If text appears in white, this means it is too long to fit on the display. If possible, break the text into smaller segments.)

For example, these pictures show how the message you just created would appear on a one-line Alpha® 215C sign.

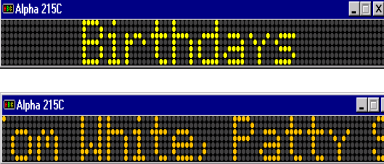



11. Save this message by selecting *File>Save* and then clicking *OK*:

Make sure the file is saved to this folder.

Name the Example 1 message *Alpha1.msw*.

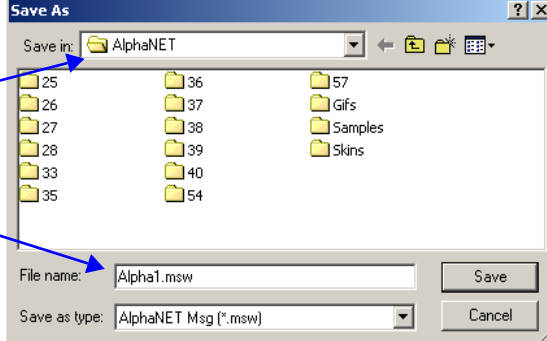

Using characters to change the look of a message

Characters are options that change the appearance of text in a message. For example, normal-sized text (called *Seven Row Normal*) is seven rows of LEDs high, but some signs allow you to create text 15 or 16 rows high with the *15/16 Row Normal* option. In this example, we will create a message that displays airline fares.

NOTE: Some characters are not available on some signs. For a list of what is available, see “Appendix C — Character fonts and colors available on signs” on page 139.

Example 2: How to display airline fares.

In this example, the *Roll* mode, *15/16 Row Normal* text, and the *New Line* option are used to display airline prices for several cities. Just like Example 1, this setup has a variety of uses, such as announcements and anniversaries.

A single message will be used to create large text on two-line signs and normal text on one-line signs.

12. Select *File>New* to open a new message.

13. Then select *Modes>Roll>In*:

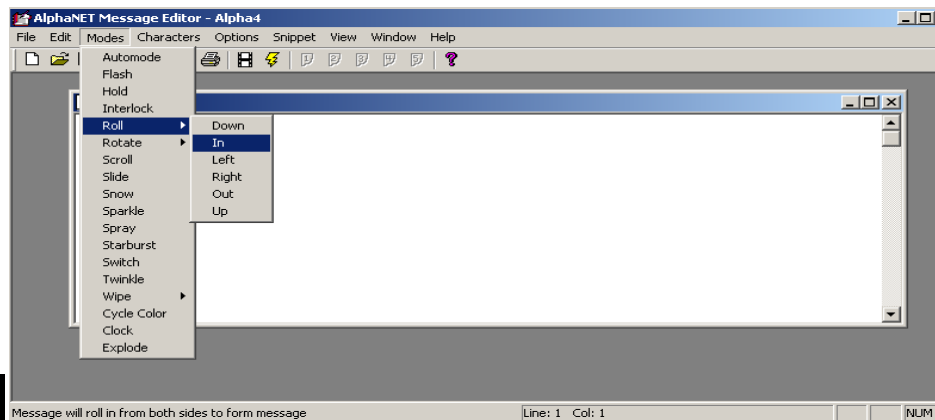

OOPS!

By selecting *Top*, we have made an error that will show up later.

The purpose of this is to demonstrate a common mistake and how to correct it.

14. When the following window appears, select *Top* and then *OK*:

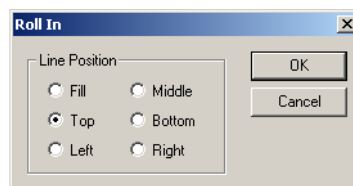

- 15.** Because we want large text, select *Characters>15/16 Row Normal*. Then type *Las Vegas \$85, Chicago \$199, New York \$235*:

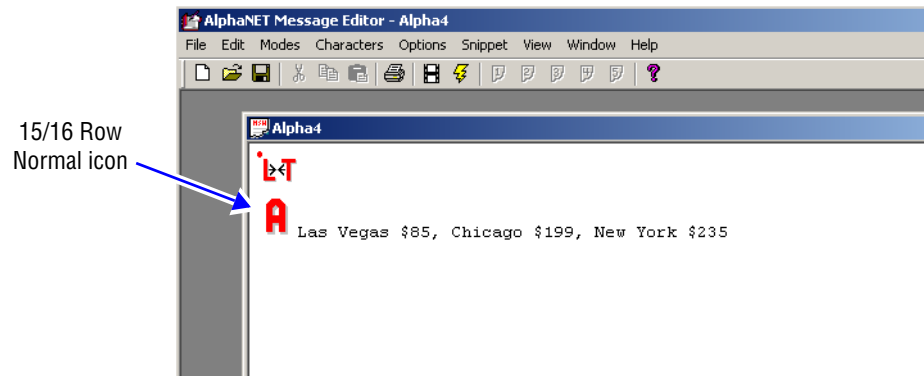
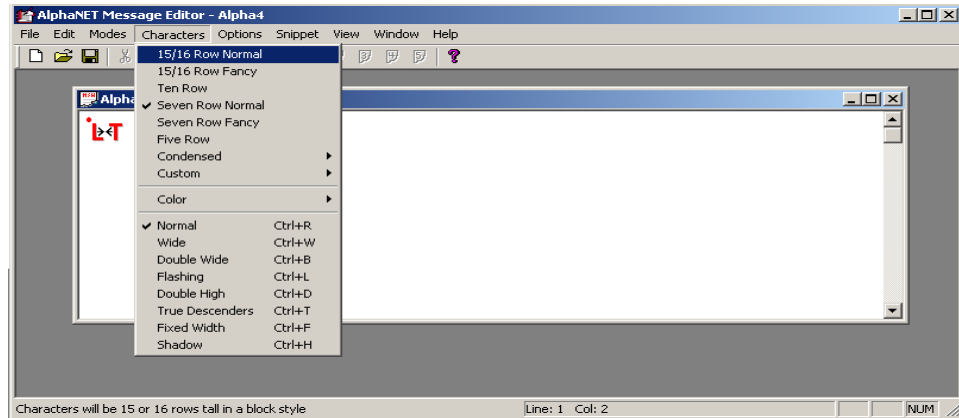

- 16.** Let's see how the message looks so far. First, let's try a one-line sign. Simulate your message and change the sign to a 215C. (If you do not remember how to do this, see step 3.) The message should look like this:

Since a one-line sign like the 215C cannot display the *15/16 Row Normal* characters, the sign displays *Seven Row Normal* instead. But this is what we wanted.



- 17.** Change the sign to a 4120C, a two-line sign. (If you do not remember how to do this, see step 3.) This is how it should look:



Why doesn't the large text appear on the two-line 4120C sign like we wanted? Because in a previous step we selected the *Top* instead of the *Middle* or *Fill* line position:

To make the large *15/16 Row Normal* text appear correctly, the line position must be changed to *Middle*.

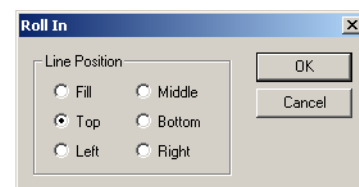

- 18.** To make the large *15/16 Row* characters appear correctly on a two-line sign, start by deleting the *Roll>In* icon from the message:

To delete the *Roll In* icon, place the cursor to the *right* of the icon and press the *BackSpace* key on your keyboard.

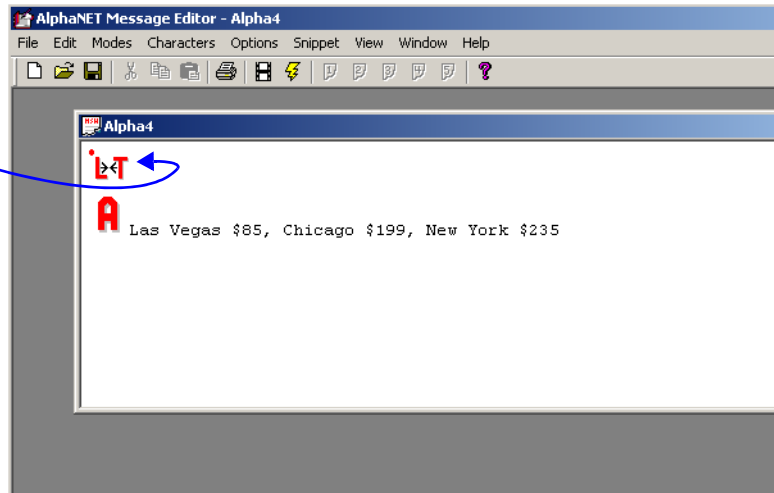

- 19.** Next, without moving the cursor in the message, select *Modes>Roll>In* as you did before. When the following window appears, select the *Middle* line position:

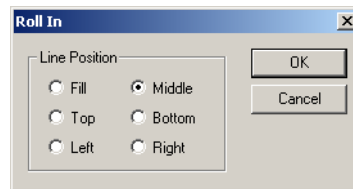

- 20.** Simulate the message using a two-line sign like the 4120C. (If you do not remember how to do this, see step 3.) The *15/16 Row Normal* text should now appear correctly:



Your message text should look like this:

Notice that this marker on the *Roll>In* icon has changed to the middle, indicating the new line position.

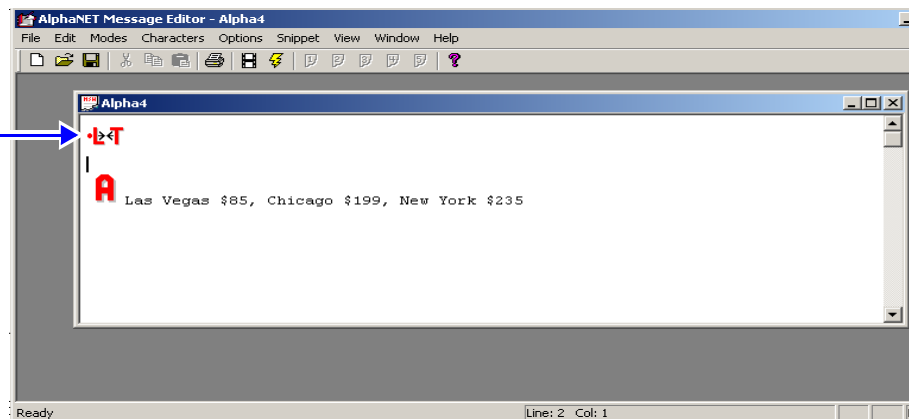

21. Save your message and name it *Alpha2.msw*. However, keep using the message for the following steps.

22. Now we will try displaying a city name and dollar amount on a sign at the same time.

Try deleting the comma and space between each city and amount pair. Then place a carriage return after each, like this:

OOPS!

Using a carriage return might seem like the logical way to format lines of text in a message, but it does not work.

We will correct this later with the *New Line* option.

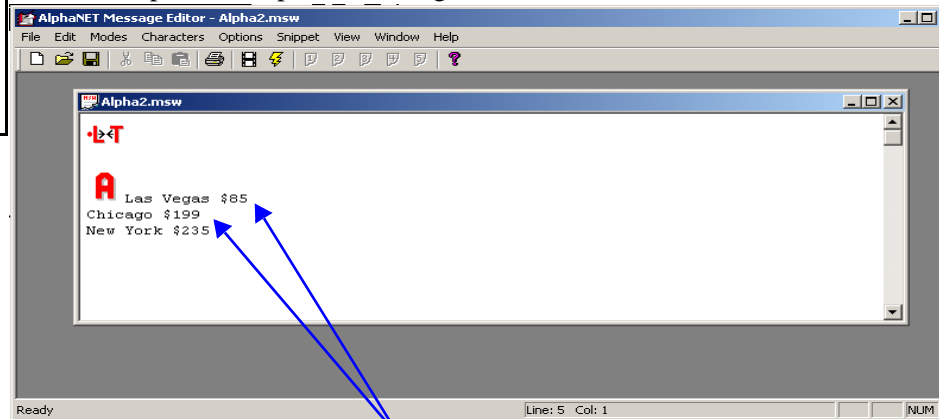

A carriage return has been placed after each line of text.

23. Next, simulate the message to see how carriage returns affect the message format. This is what you should see:

Carriage returns do not break text into separate lines.

The *New Line* option must be used instead.



24. To format the text so that *Las Vegas \$85* and *Chicago \$199* and *New York \$235* all appear on separate lines, add the *New Line* option after each city and amount pair. To do this, use the *Options* menu:

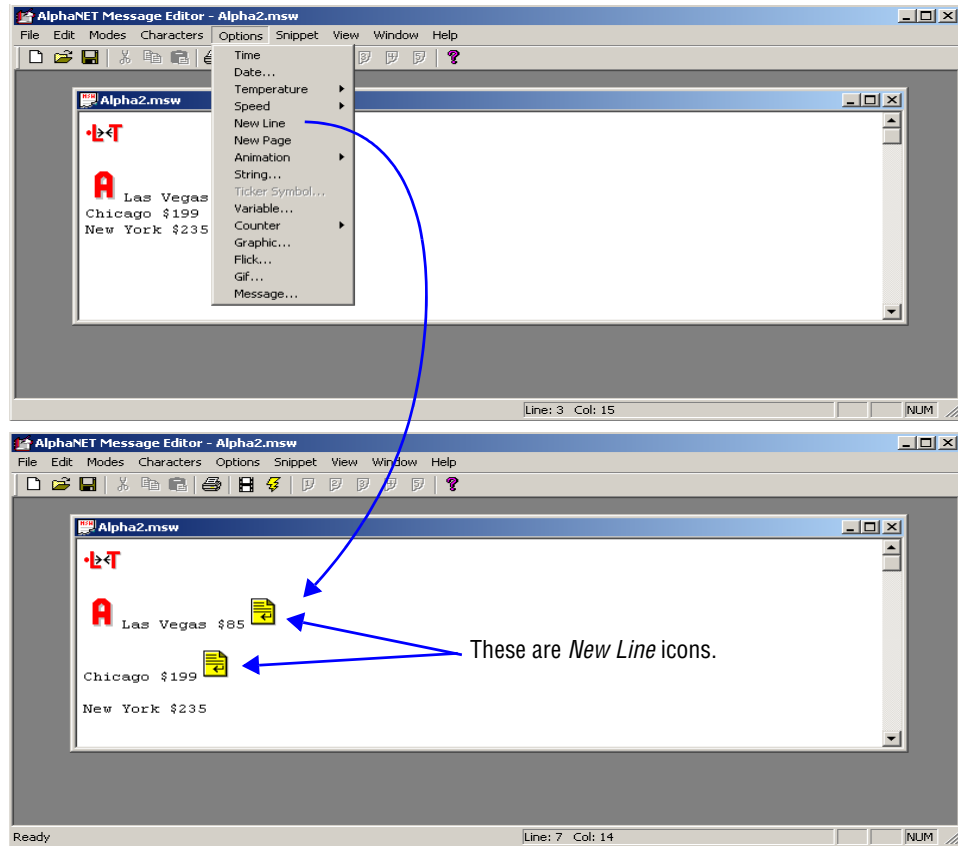

25. Simulate the message to see how *New Lines* affect the message format. This is what you should see:

The *New Line* option formats the text correctly.

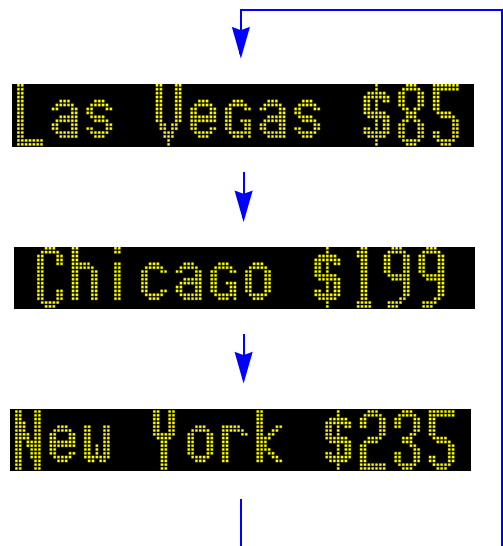

Using international characters

International characters—such as the *é* in *résumé*—are available in French, German, Italian, Spanish, and Croatian.



Additional characters are also available. Check the *Character Map* accessory to see if it contains the character you want.

NOTE: These instructions are for a Windows® 95 operating system; menu selections and screens may be different in other versions of Windows®.

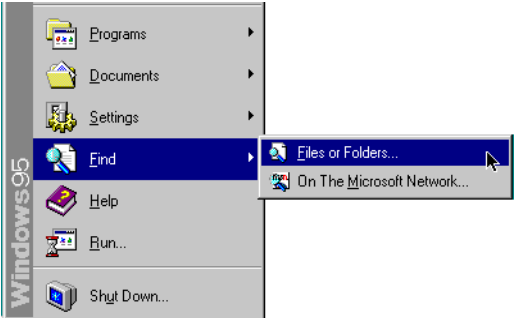
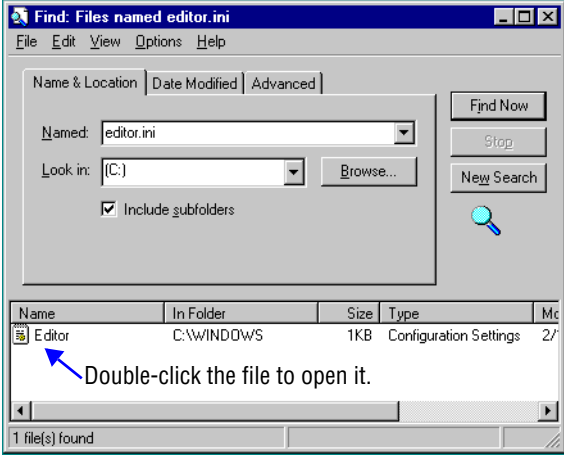
Follow this procedure to use international characters:

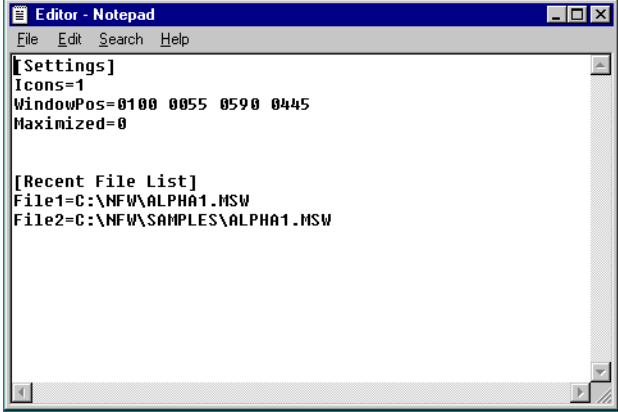
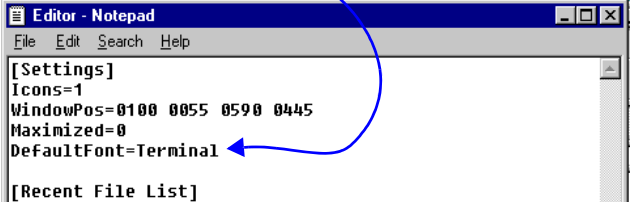
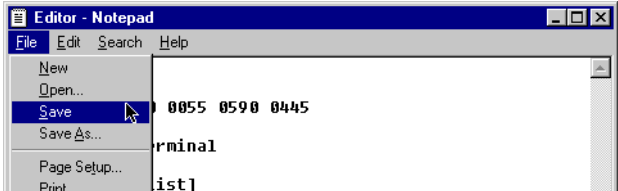
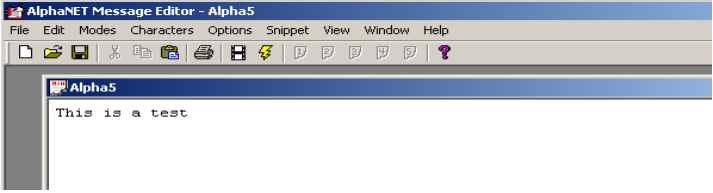
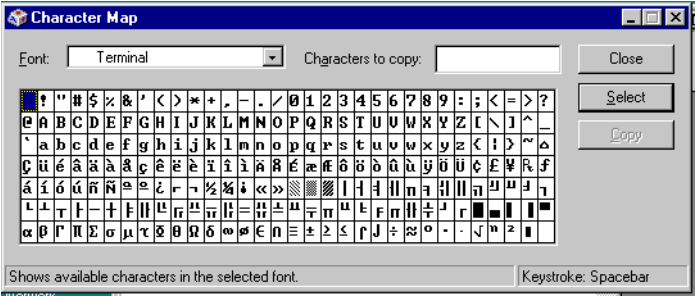
Step	Procedure
1	<p>From the Windows® <i>Start</i> menu, select <i>Find</i> and then <i>Files or Folders</i>:</p> 
2	<p>Use <i>Find</i> to locate the <i>editor.ini</i> file and then double-click it to open:</p> 

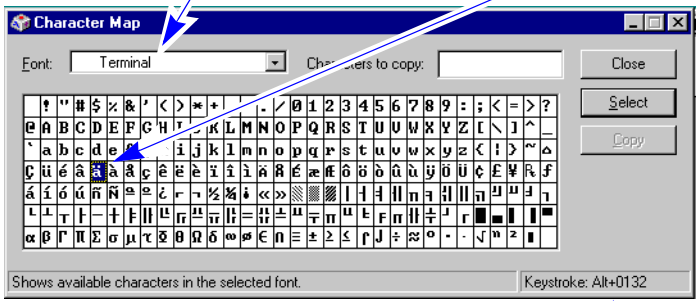
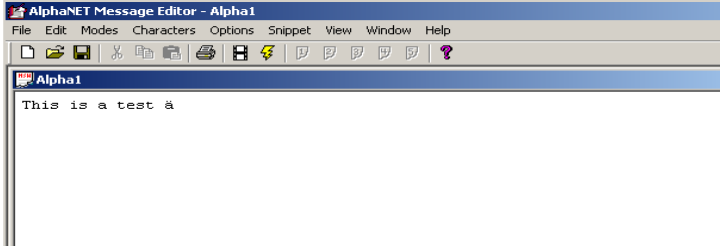
Step	Procedure
3	<p>The <i>editor.ini</i> file will look something like this:</p> 
4	<p>Type the following line exactly as shown: DefaultFont=Terminal</p> 
5	<p>Then save the change and exit this window:</p> 
6	<p>Next, open <i>Message Editor</i>. Select <i>File>New</i>. Type <i>This is a test</i>.</p> 
7	<p>From the Windows® <i>Start</i> menu, select <i>Programs>Accessories>Character Map</i> (or <i>Program>Accessories>System Tools>Character Map</i>):</p> 

Step	Procedure
8	<p>Imagine you want to add the letter <i>ã</i> to your message:</p> <p>First, set <i>Font</i> to <i>Terminal</i>. Second, click the letter <i>ã</i>.</p>  <p>Third, note the keystroke. You must hold <i>Alt</i> and type <i>0132</i> to create the international character <i>ã</i>.</p>
9	<p>Return to <i>Message Editor</i>. Add the <i>ã</i> character to the message by typing <i>0132</i> while holding down the <i>Alt</i> key on your keyboard:</p> 
10	<p>Finally, to make sure you have actually created the character you want, simulate the message:</p>  <p>NOTE: You cannot use characters created by holding down the <i>Ctrl</i> key and typing the combination. For example, you will not be able to use the Ç character because it is created by using <i>Ctrl</i> and 2.</p> <p>Also, you can only use <i>Alt</i> with numbers less than 0169 to create characters.</p> <p>For example, you can use <i>Alt</i> and 0168 to create the letter ç, but <i>Alt</i> and 0169, <i>Alt</i> and 0170, and so on, will not create the correct characters and should, therefore, not be used.</p>

How to send a message to a sign

What happens when messages are sent to a sign?

Messages are sent to signs using either *Message Editor* or *Site Manager*. One message at a time is sent from *Message Editor*, and it erases all other messages in the sign's memory. This one message, then, plays over and over.

More than one message at a time can be sent from *Site Manager*, and they erase all other messages in the sign's memory. These new messages are then displayed one after the other.

When a single message is sent with *Message Editor*:

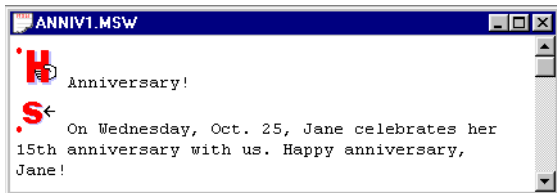

After creating a message in *Message Editor*,

select  to send the message to one or more sites.

Each message packet sent includes the date and time from the sending PC. The clock inside the sign will be updated, even if the message doesn't include the date or time.

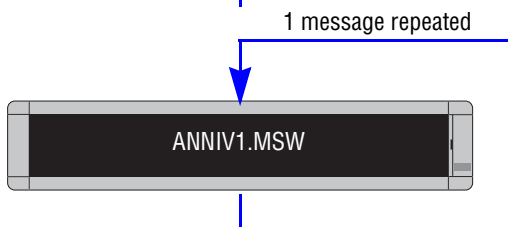

When more than one message is sent with *Site Manager*:

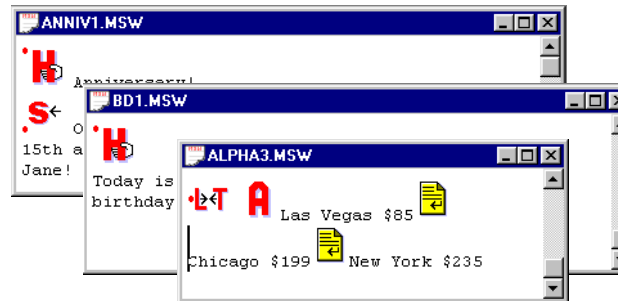

After creating messages in *Message Editor* and then saving them, open *Site Manager*. Select the sites to which you want to add messages, then click .

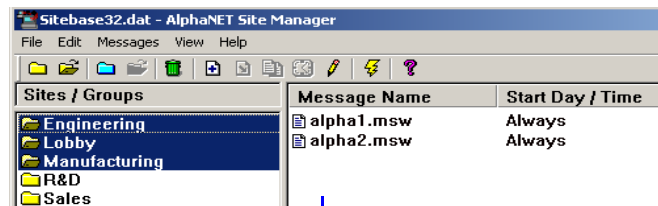

Then select  to send the messages.

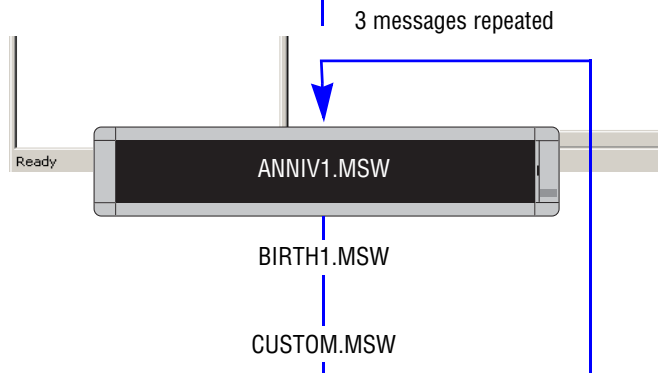

Sending messages from Message Editor

HINT

Generally, only send messages from *Message Editor* when:

- testing to see how a message looks, or
- there is only one sign.

1. Before sending a message, you must create at least one site using *Site Manager*. (See Step-by-step tutorial in setting up connection devices, sites, and groups in Chapter 2.)

2. Next, create your message in *Message Editor*. When you are finished, send it to one or more sites:

Click  to transmit the message:

- *To All Sites* — every site you have created in *Site Manager* or
- *To Selected Sites* — only those *Site Manager* sites that have been specially selected as *Use as an Editor transmit site*. (See “R & D setup (1 of 4): Site Editor (Site Info) window” on page 30 in Chapter 2.)

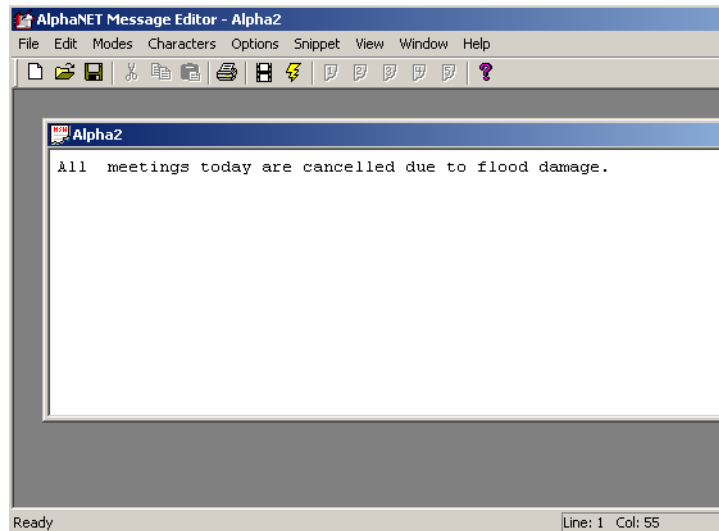

Sending messages from Site Manager

HINT

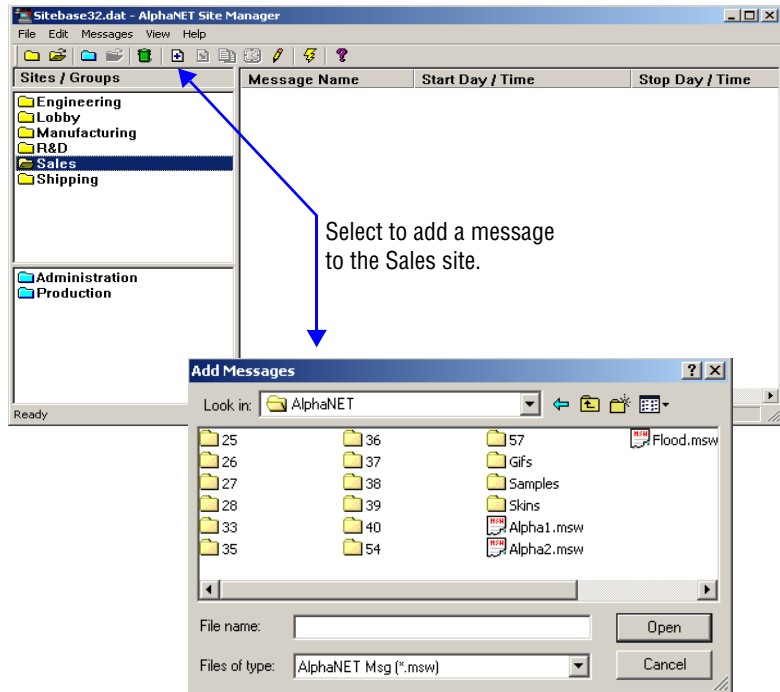

To select more than one site, first hold down the *Ctrl* key on your keyboard, then click the sites:

1. Before sending a message, you must create at least one site using *Site Manager*. (See Step-by-step tutorial in setting up connection devices, sites, and groups in Chapter 2.)
2. If you have not already done so, add your message to the site (or sites) to which you want the message sent:

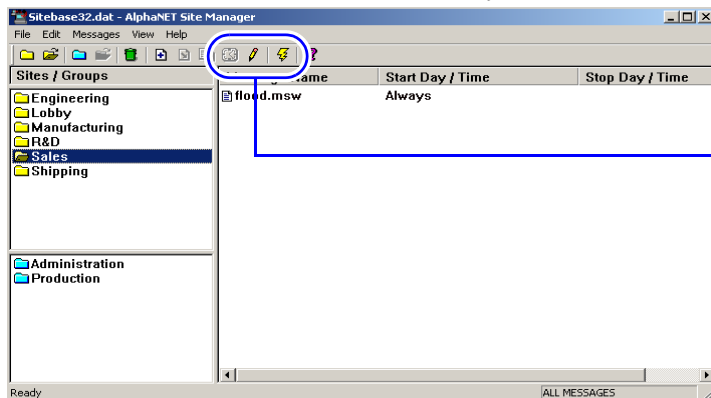

3. Next, select the message. The message can be edited, scheduled by day, date, and time, or transmitted immediately:



- Select  to set the day, date, and time when the message will start and stop on the Sales signs, or
- select  to edit the message in *Message Editor* before sending it, or
- select  to transmit the message immediately to all the signs in the Sales site.

The difference between all messages and common messages

When you select a single site, all the messages attached (added) to the site will appear in the *Site Manager* window. However, when you select more than one site, only the messages that are common to both will appear.

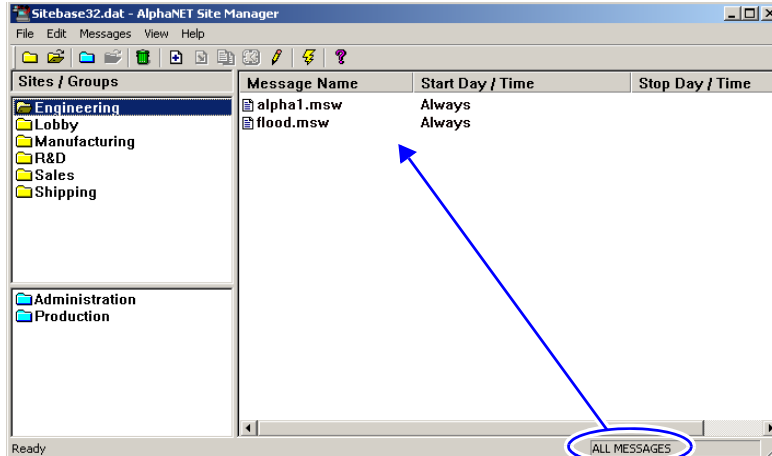

When the Engineering site is selected, all the messages attached to the site appear.

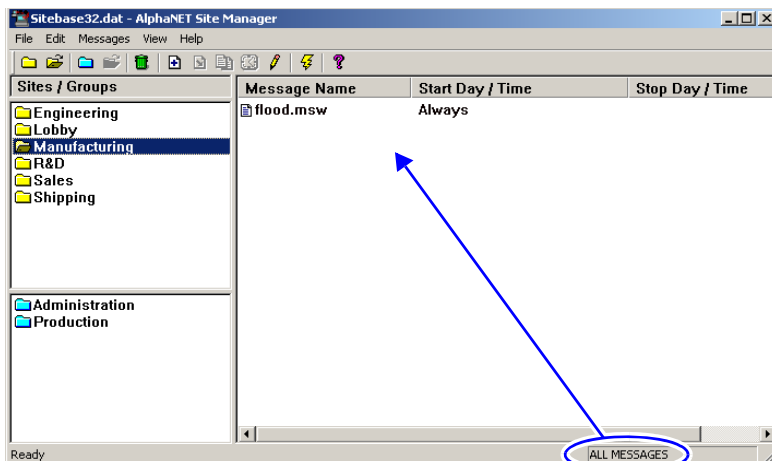

Also, when the Manufacturing site is selected, all the messages attached to the site appear.

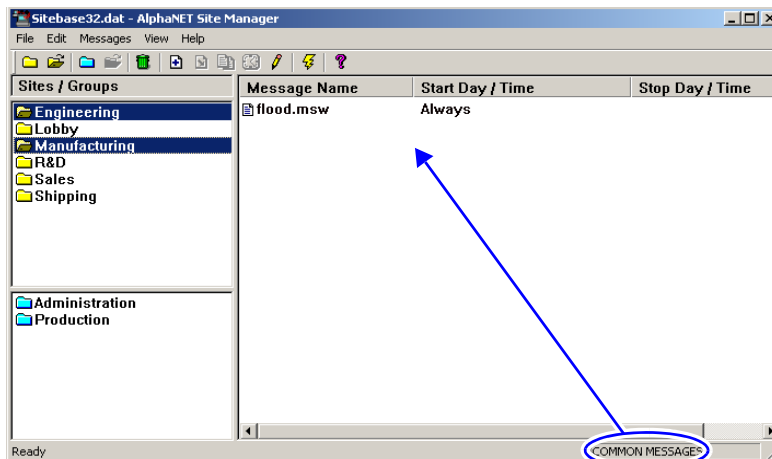

However, when both sites are selected, then only the messages that are common to both sites will appear.

How to use graphics in messages

HINT

Example graphic files are included with AlphaNET™ 3.0 software.

Look in the Samples folder installed on your computer.

The *Animation*, *Graphic*, *Flick*, and *Gif* options allow you to include small pictures in messages. Use the *Graphic* option to display single bitmapped images, and the *Animation*, *Flick*, or *Gif* option to display multiple images—like a movie. Note that not all signs display animations.

For the *Graphic*, *Flick*, and *Gif* options, you can create the images yourself, use the animations provided (such as Running Animal, which shows a horse running across the sign), use the gif files provided, or pull an image from another source, such as the Internet.

Animation, *Graphic*, *Flick*, and *Gif* are in the *Options* menu:

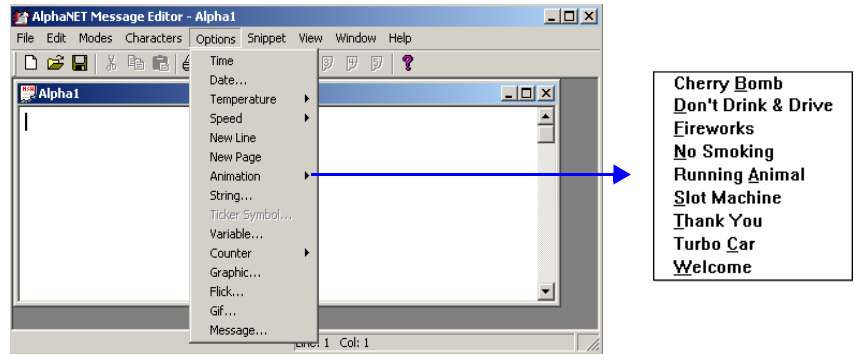

Creating a graphic

Before you actually start drawing, make sure you understand how a bitmapped image is displayed on a sign. See “Graphics must be bitmapped to a sign’s columns and rows” on page 149.

You will need a program to create and edit bitmapped images. Image editing software examples in this manual illustrate version 5.03 of Paint Shop Pro (the steps are similar for newer versions of Paint Shop Pro).

Any image editing program can be used (See “Paint Shop Pro — an image editor” on page 150.)

Example 3: How to use a graphic in a message

In this example, arrow bitmap images are created to demonstrate the *Graphic* option.

The two arrow bitmaps we will make are 7 rows (or pixels) high. This means the arrows can be used on one-line as well as two-line signs.



1. Select *Start>Programs>Paint Shop Pro* to open Paint Shop Pro:

HINT
 Most image editing programs create images similar to Paint Shop Pro.
 However, if you are not using Paint Shop Pro, consider using software that has a zoom feature so you can increase the size of the bitmap for ease of editing.

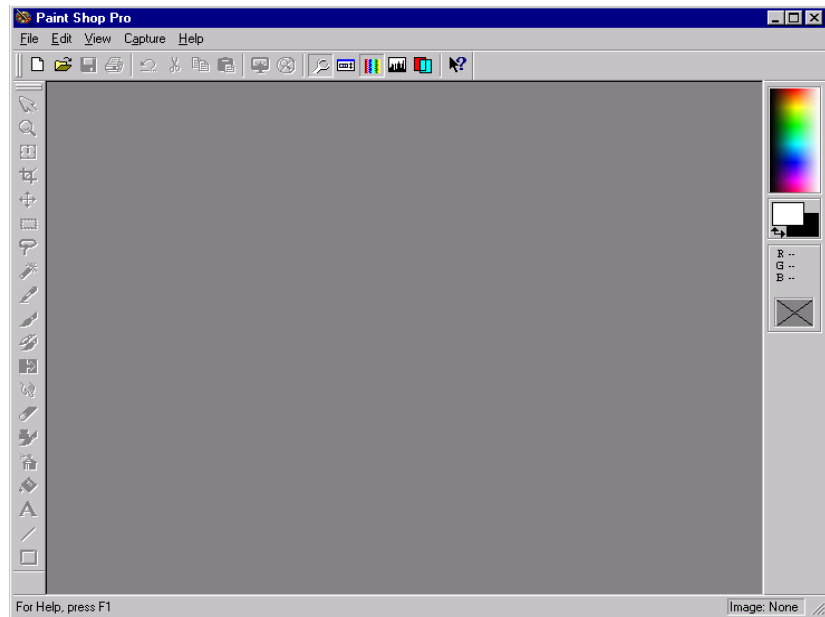

2. Next, select *File>New*. When the *New Image* window appears, make the width and height of the new bitmap 16 x 7:

NOTE: *Width* and *Height* define the size of the bitmap in pixels—16 pixels wide x 7 pixels tall. These numbers also correspond to a sign’s columns and rows—16 columns wide x 7 rows tall.

HINT
 Because a maximum of 8 colors can be used on signs, select 16 colors instead of 256 in your image editing program.

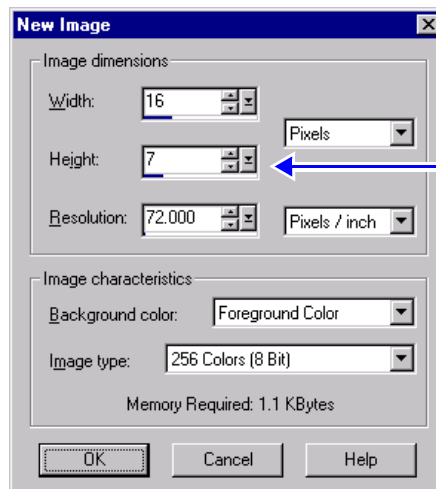

We are using 7 because this is the height of a single line of normal text on a sign.

3. A very small window will appear. Use the zoom tool to click in the window to increase its size to 16:1:

HINT

Use the zoom feature to increase the size of the small window until the window says 16:1.

At 16:1, editing the graphic is much easier.

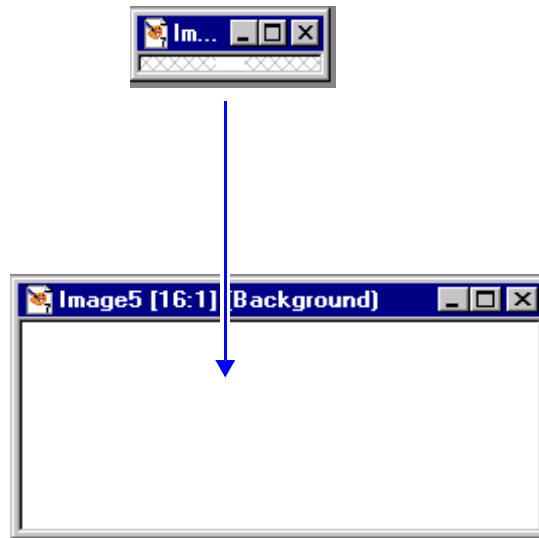

4. Select a color for your graphic from the blended palette on the right-hand side of your screen. You can also double-click the foreground or background rectangle underneath the blended palette to choose a color from a sectioned palette.

HINT

Depending on the model of the sign some colors do not effectively appear on the sign display.

For more information see "A graphic may be the wrong color for some signs" on page 149.

The sectioned palette →

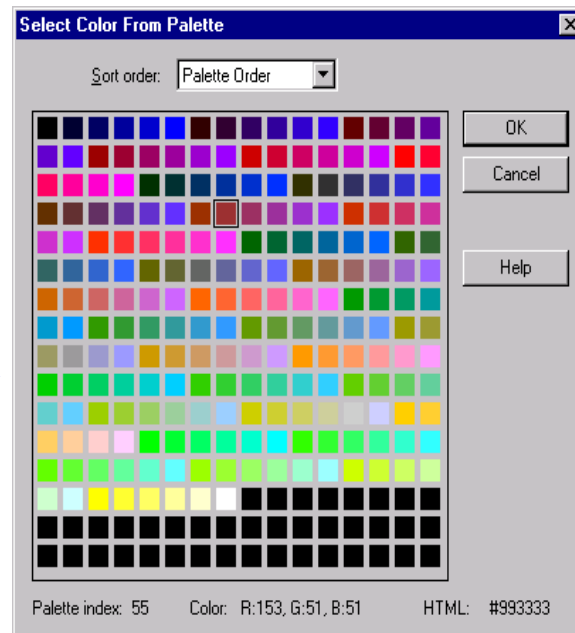

- Then draw the right arrow and save it as a BMP bitmap named *rarrow.bmp*:

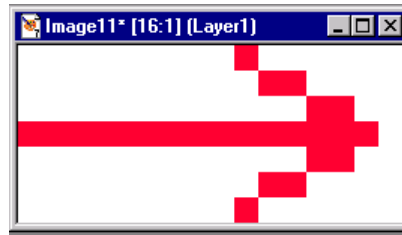

Name the graphic *rarrow.bmp*.

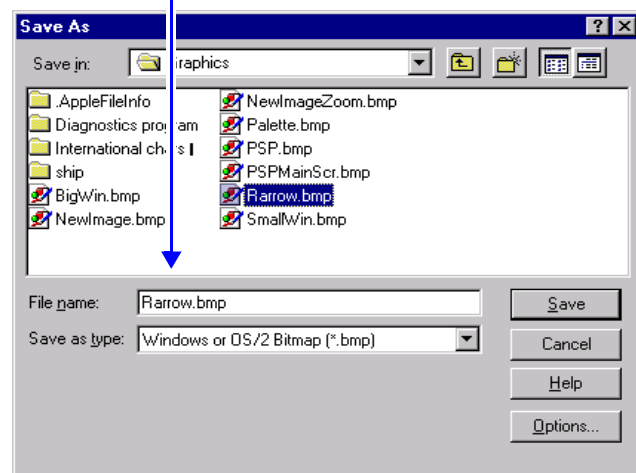

- Create the other arrow (shown below) using steps 2 through 4 and save it as *larrow.bmp*:

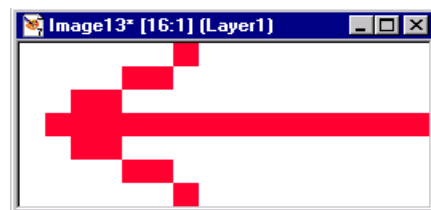

- Next, open *Message Editor*. Then select *File>New*:

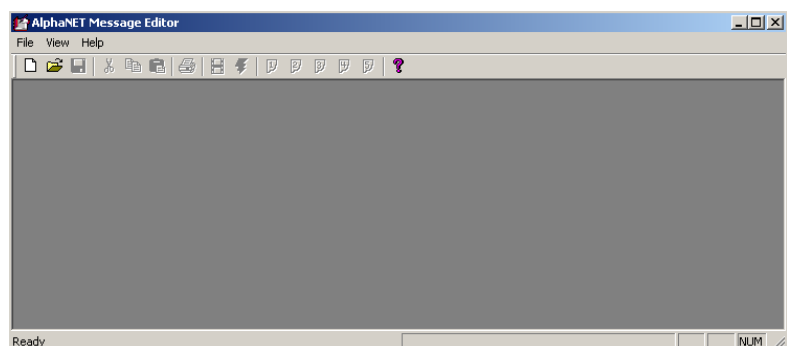

8. Select *Modes>Hold*, using the *Middle* line position. Then select *Options>Graphic*. When the *Select Graphic* window appears, choose the *rarrow.bmp* (right arrow) file you just created:

NOTE

For graphics, any mode can be used. For flicks, the *Hold* mode must be used.

For either graphics or flicks, the mode selected must use the *Middle* line position.

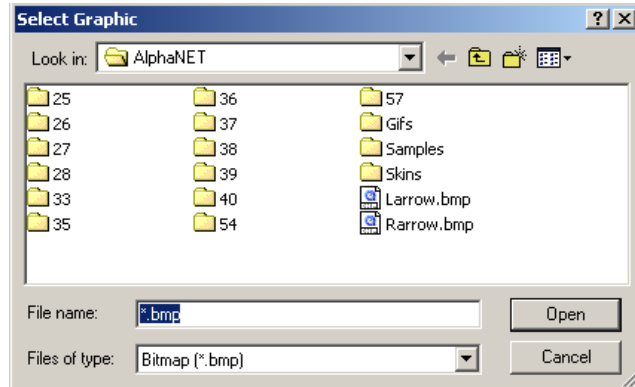

9. An icon representing the graphic will appear. Type *News* after it. Put a space before and after *News*. Finally, put the left arrow bitmap (*larrow.bmp*) after *News*. This is what you should now see:

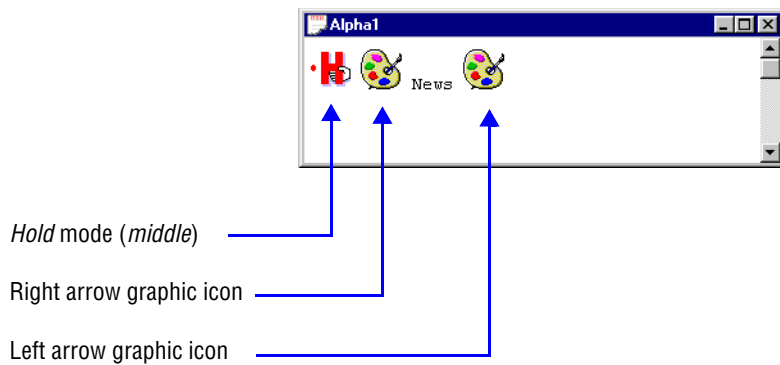

10. Simulate your message to see what it looks like:

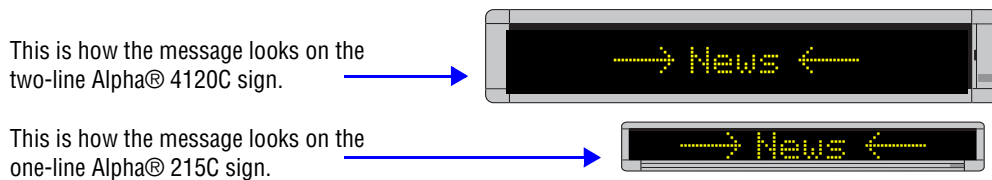

Note:Graphics that are 24 rows high should be displayed and simulated on 3-line signs (or greater) and not on one- or two-line signs where the graphics will appear garbled.

Creating a flick

NOTE: The *Flick* option only works with AlphaVision™ and Series 7000 signs. However, see “Another way to create a flick” on page 76 to create an animation on another type of sign.

A flick is a series of bitmap images that are shown one after the other, which gives the illusion of movement on a sign. The *Flick* option is used to put a movie in a message, and is made up of individual bitmapped images that you must create.

You will need a program to create and edit bitmapped images. Image editing software examples in this manual illustrate version 5.03 of Paint Shop Pro (the steps are similar for newer versions of Paint Shop Pro).

Any image editing program can be used (See “Paint Shop Pro — an image editor” on page 150.)

Example 4: How to use a flick in a message

In this example, we will create a ship that sails across an Alpha® 7120C sign.



A flick is made up of many bitmap files that are played one after the other.

Each bitmap file in a flick must fill the total display area of the sign it is displayed on. This means that a flick is usually designed for one sign.

In this example, each bitmap is 120 x 24 pixels because we are playing the flick on a 7120C sign whose total display area is 120 columns x 24 rows.

1. Select *Start>Programs>Paint Shop Pro* to open Paint Shop Pro:

HINT

Most image editing programs create images similar to Paint Shop Pro.

However, if you are not using Paint Shop Pro, consider using software that has a zoom feature so you can increase the size of the bitmap for ease of editing.

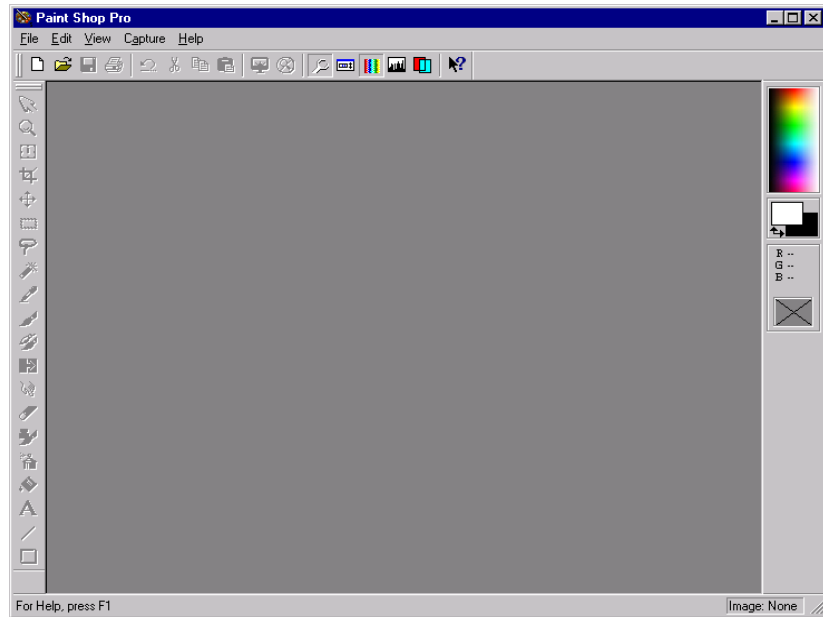

2. Next, select *File>New*. When the *New Image* window appears, make the width and height of the bitmap 120 x24 pixels.

Each graphic in the flick for the Alpha® 7120C sign must be this size.

NOTE: *Width* and *Height* define the size of the bitmap in pixels—120 pixels wide x 24 pixels high. These numbers correspond to the 7120C’s columns and rows—120 columns wide x 24 rows tall.

HINT

Because a maximum of 8 colors can be used on signs, select 16 colors instead of 256 in your image editing program.

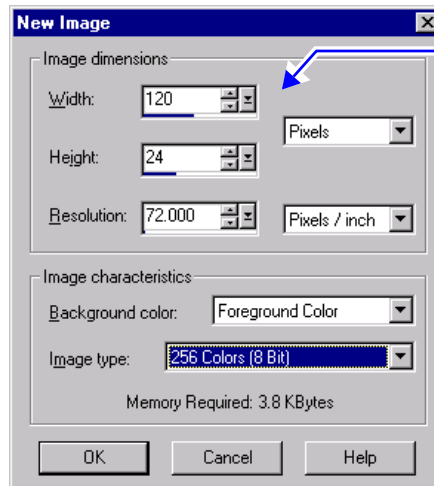

We’re using 120 x 24 for width and height because this is the total display area of an Alpha® 7120C sign.

3. A very small window will appear. Use the zoom tool to click in the window to increase its size:

Use the zoom feature to increase the size of the small window to make editing the graphic much easier.

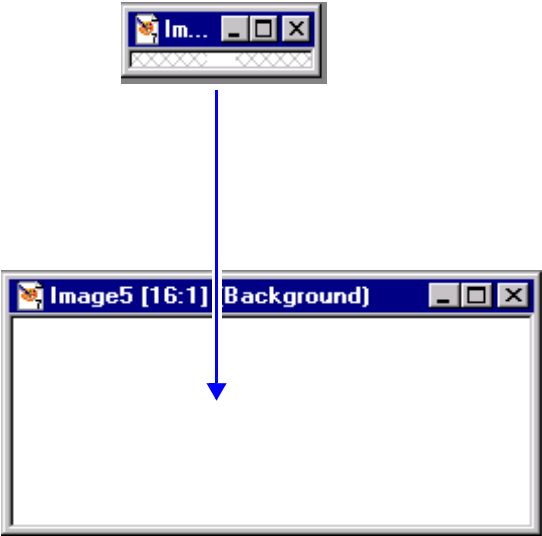

4. Select a color for your graphic from the blended palette on the right-hand side of your screen. You can also double-click the foreground or background rectangle underneath the blended palette to choose a color from a sectioned palette.

HINT

Depending on the model of the sign some colors do not effectively appear on the sign display.

For more information see "A graphic may be the wrong color for some signs" on page 149.

The sectioned palette →

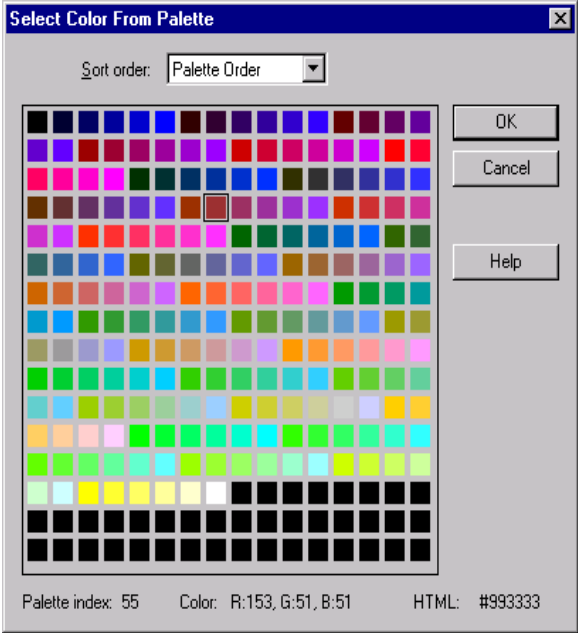

5. Then draw the first bitmap image:

The first bitmap in this flick will show a ship entering from the left side of the sign.

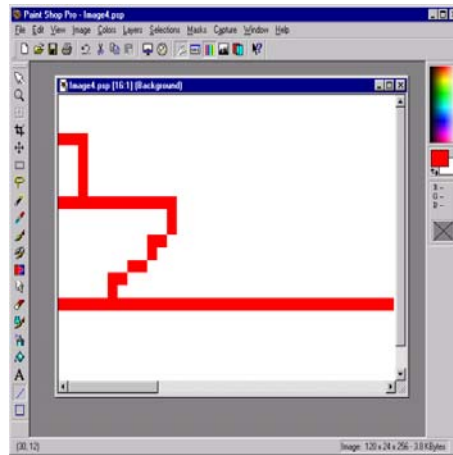

6. After you are finished drawing the first bitmap, save it—and all the other flick bitmaps—in a folder named *ship*.

Name this first bitmap *ship00.bmp* and save it as a BMP file:

HINT

Even though up to 100 bitmaps can be in a flick, keep in mind that a sign's memory capacity is limited.

So experiment first with small flicks on a sign.

NOTE: The name of each bitmap in a flick is important. The first bitmap's name must end with *00*, such as *ship00.bmp*. The second bitmaps's name must end with *01*, such as *ship01.bmp*. The third bitmap's name must end with *02*, such as *ship02.bmp*, and so on. Up to 100 bitmaps can be in a flick and must be numbered 00 to 99, such as *ship00.bmp* through *ship99.bmp*.

Save all the flick bitmaps in the special folder you created.

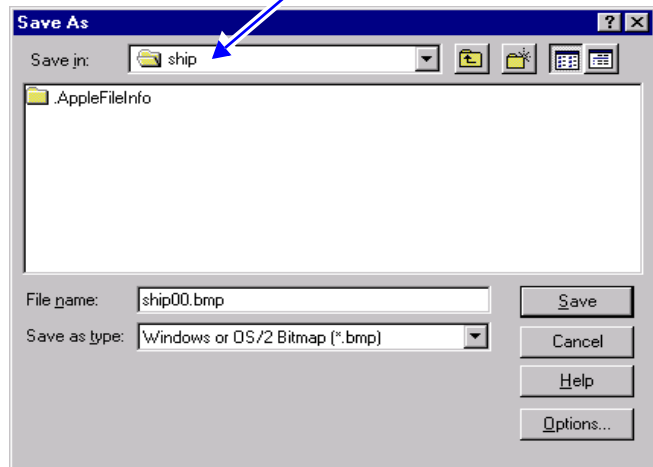

- 7.** Create the other bitmaps in the flick. Each bitmap file must end with a consecutive number—00, 01, 02, and so on—and each bitmap must be saved as a BMP file in a special folder for the flick (*ship*, in this case).

The completed flick of 11 bitmaps shows a ship crossing the screen. When the ship is about mid-screen, a submarine periscope appears in front of the ship. The periscope disappears as the ship passes above it, but pops up again behind the ship, looks around, then goes under water.

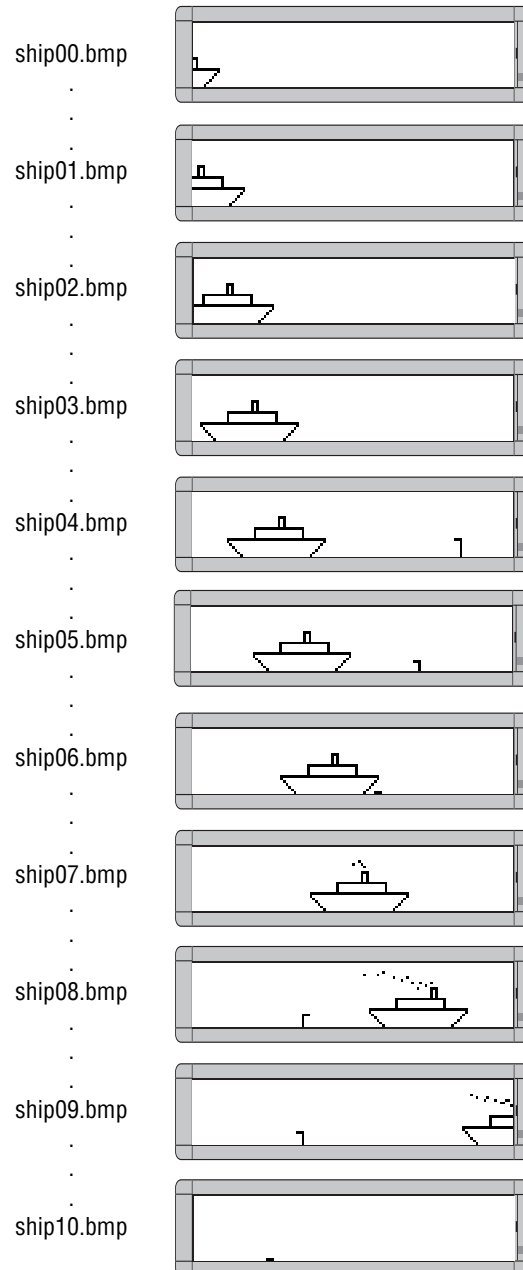

Another way to create a flick

Though the *Flick* option will only work with AlphaVision™ and Series 7000 signs, there is another way to create the illusion of motion on a sign.

The *Graphic* option can be used to place one graphic after another in a message:

Use the *Hold* mode (with the *Middle* line position) and *Speed (No Hold)* option in front of the graphics.

This is necessary in order to turn off the *Automode* feature so that the graphics will display correctly.

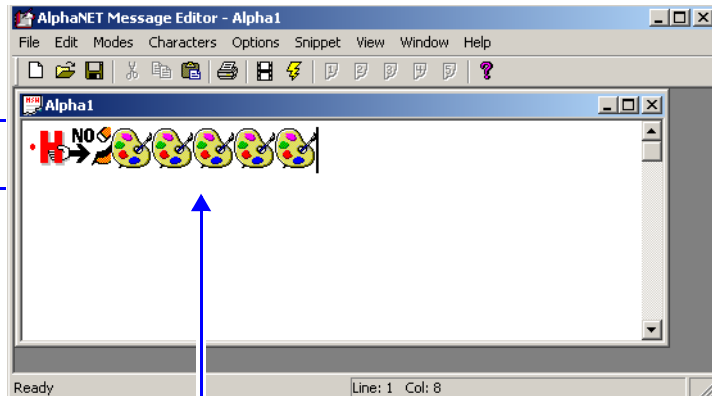

ship00.bmp through ship05.bmp

Creating a GIF

HINT

Most image editing programs can create GIF images similar to Paint Shop Pro Animation.

However, if you are not using Paint Shop Pro Animation, consider using software that has a zoom feature so you can increase the size of the bitmap for ease of editing.

NOTE: The GIF option will only work with the 7000 series, 9000 series, AlphaVision™ (full matrix), and AlphaEclipse™ signs. If a different sign is used, *Extended Memory* must be checked on the *Sign Info* tab of *Site Editor* in order for this feature to work.

A GIF contains multiple images in one file that simulate animation, such as a hummingbird hovering above a flower. The GIF option is used to put moving animation in messages, and you can use the GIF files provided or create your own (see the example below). Note that GIF files are available on Adaptive's Web site at <http://www.ams-i.com/Pages/gif.htm>, free and formatted.

You will need a program to create and edit your GIF images. Image editing software examples in this manual illustrate version 5.03 of Paint Shop Pro (the steps are similar for newer versions of Paint Shop Pro).

Any image editing program can be used (See "Paint Shop Pro — an image editor" on page 150.)

The following instructions explain how to create a GIF using Paint Shop Pro Animation.

1. Using your Internet browser, log onto the Adaptive Micro Systems Web site at <http://www.adaptivedisplays.com/sample.htm>.
2. In the upper right-hand corner of Adaptive's main page, right-click on the *Tell a Friend* graphic and select *Save Picture As*.



Right-click on this graphic and select *Save Picture As*.

3. Save the file as a GIF file to your C:\Program Files\Adaptive Micro Systems\AlphaNET directory.
4. Select *Start>Programs>Paint Shop Pro>Animation Shop*, or open the image editing program you are using.
5. Select *File>Open* and select your GIF file. Then click *Open*.
6. Change any colors in the GIF file if they are incompatible with your sign.

Note: If black or white is used in a GIF or BMP file, the sign thinks you want it to turn off those particular LEDs. Try using a different color.

HINT

Depending on the model of the sign some colors do not effectively appear on the sign display.

For more information see "A graphic may be the wrong color for some signs" on page 149.

7. Select *Edit>Resize Animation* and resize the file to your sign's specifications. Make sure the *Maintain aspect ratio* box is checked, and then click *OK*:

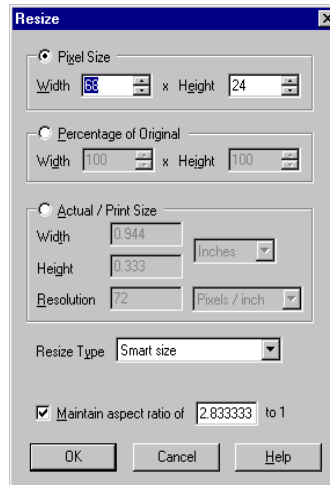

8. Select *File>Save*. Then click the *Customize* button on the *Animation Quality Versus Output Size* window that appears.

NOTE: This window appears when you save a file for the first time and then when changes are made to it. However, the settings you enter will become the default settings until you close Paint Shop Pro Animation.

9. On the *Colors* tab, make sure the settings are as follows:

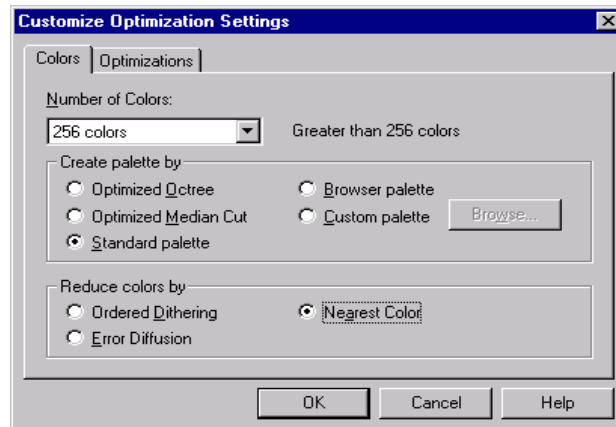

10. On the *Optimizations* tab, uncheck all the boxes and click *OK*.

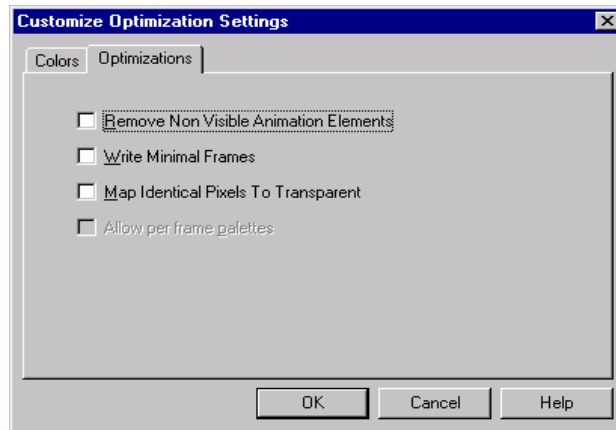

11. Click the *Next* button to cycle through the remaining windows.

12. Select *File>Close* to close your GIF file.

13. Next, open *Message Editor* and create a new message.

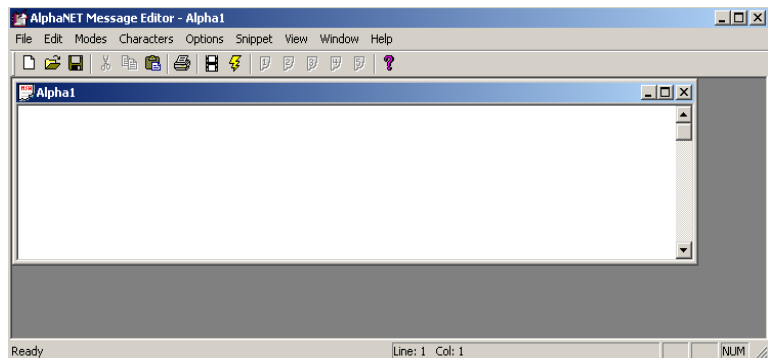

14. Select *Modes>Hold*, using the *Fill* line position.

15. Select *Option>Gif*. Then select your GIF file and click *OK*. An icon representing the *Hold* mode and one representing the GIF will appear in your message.

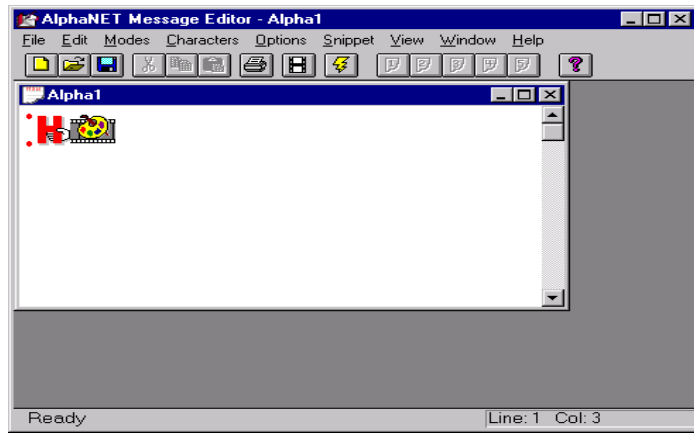

16. Simulate your message to see what it looks like:

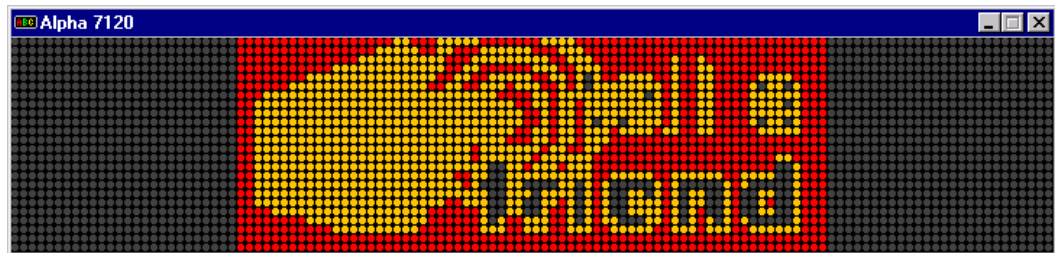

How to edit a counter file

What is a counter file?

A counter file sets up from 1 to 5 numerical counters (counter 1 through counter 5), which can be used for either or both of the following:

- ▶ **Display information in minutes, hours, or days on a sign.**

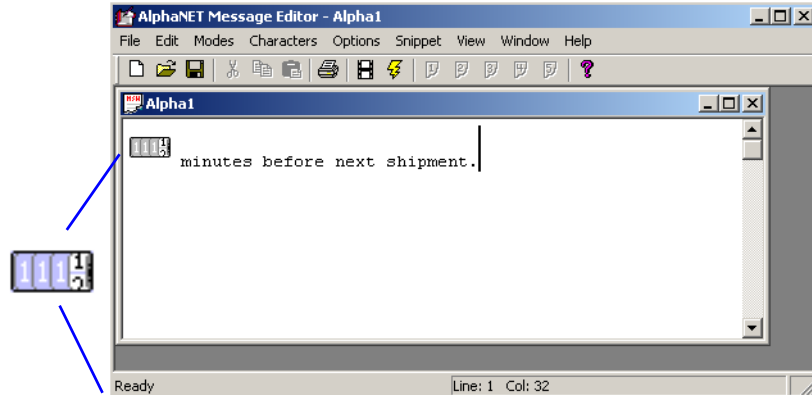

A counter can be placed inside a message.
(This one is counting down from 60 minutes.)



- ▶ **Display special messages (target files) on a sign after a set amount of time has passed.**



After 50 days, the counter included in the top message (which counts up from 0 to 50) is set up to display the target message below:

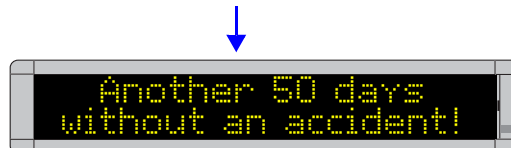

NOTE: The software necessary to use a counter file is included in the standard Alpha® firmware for signs and allows you to program a counter file from your computer. However, the standard Alpha® firmware does not allow you to program a counter file using an infrared remote control (left).

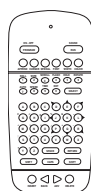

Three examples of how to use counter files

In these examples, we discuss three basic ways of using counters on signs:

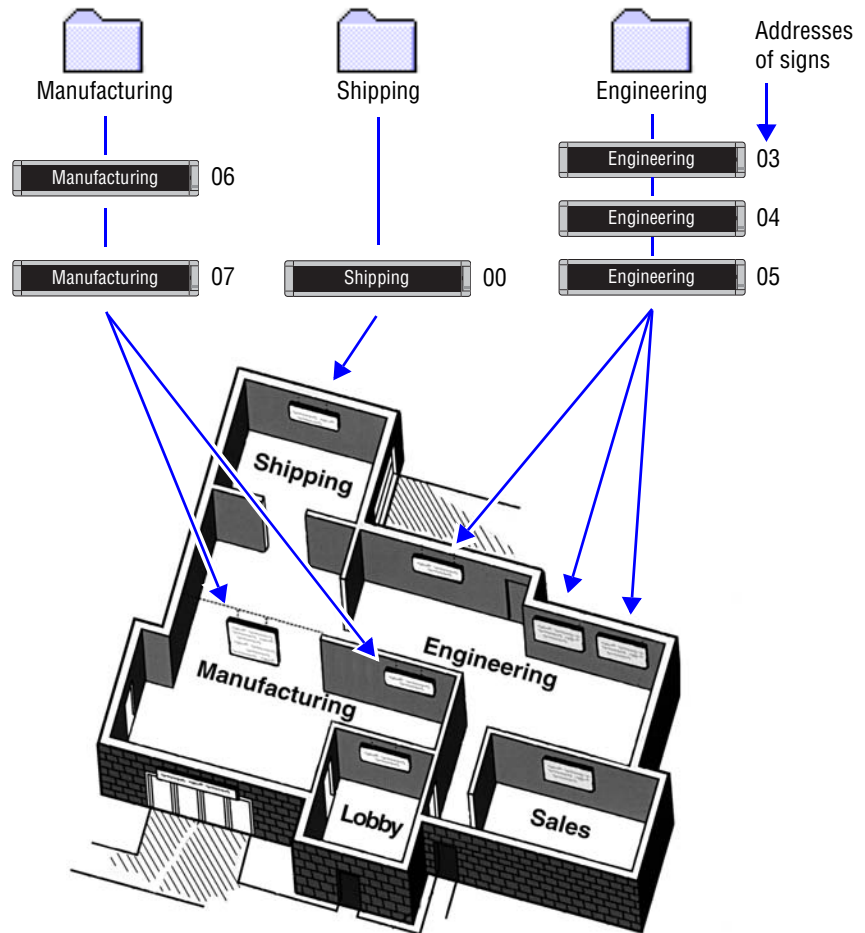

- **Example 1** — Using a counter in a message on the Shipping sign. Counter 1 will be used to show a message that counts down hours.
- **Example 2** — Using a counter in a message and displaying a target file message on the Manufacturing signs. Counter 2 will be used to show a message that counts up days and display a target message when it reaches 50.
- **Example 3** — Using a counter to display a target message on the Engineering signs. Counter 2 will be used from Example 2.

Example 1 — Using a counter in a message

In this example, we will end up with a message on the Shipping sign that counts down from 60 minutes over and over again:

NOTE: The Shipping sign can still display other messages.



1. Open *Message Editor* and create a new message:

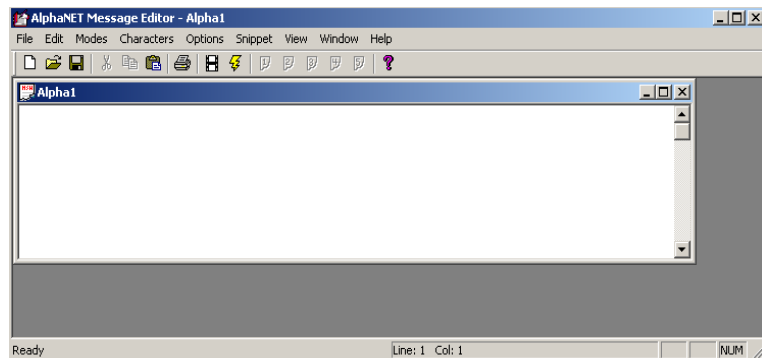

2. Add a counter to the message by selecting *Options>Counter* and then *Counter 1*. Then, after the counter icon, type a space followed by *minutes before next shipment*:

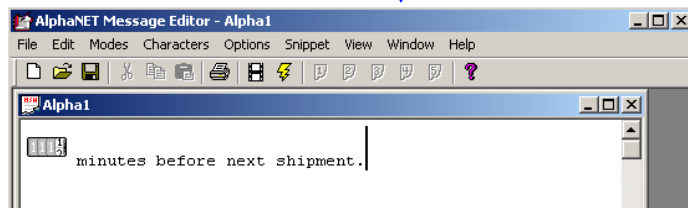
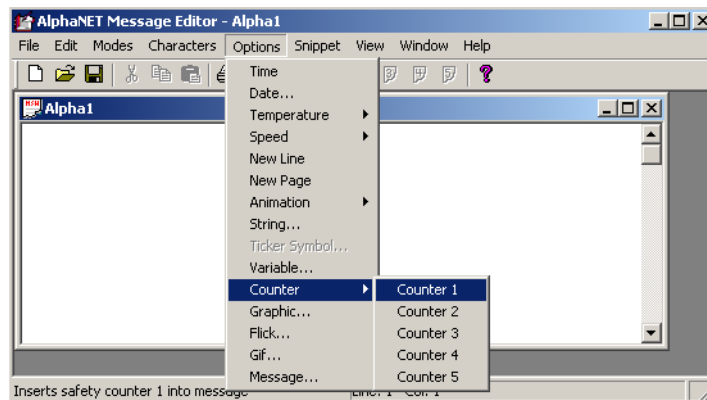

3. Save this counter message as *countshp.msw*:

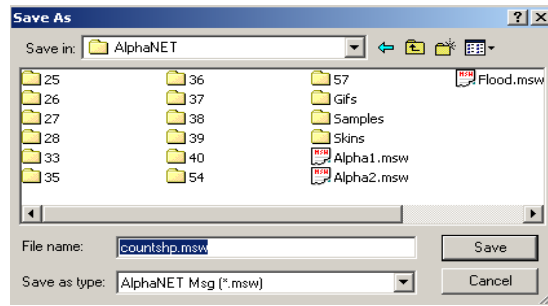

4. After saving the message, close *Message Editor*. Open *Site Manager* and select *Edit>Counter File*:

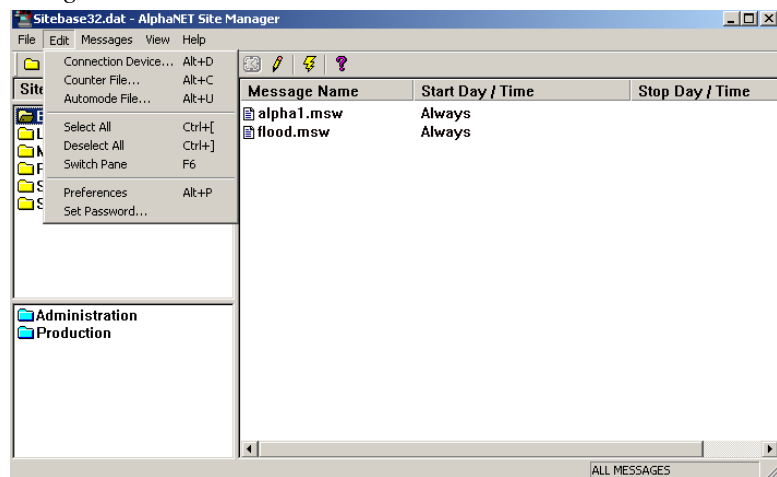

5. Next, either open an existing counter file (like the default file shown below) or type a new file name (such as *shipping.ctw*):

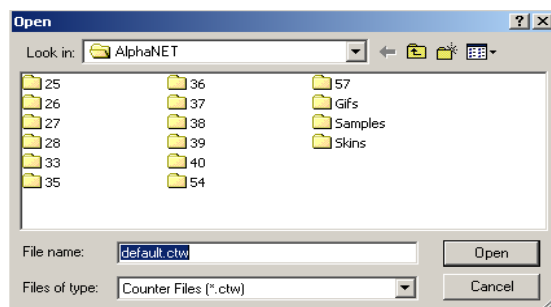

6. When the *Counter Setup* window appears, select the *Counter 1* tab. Then type in the values as shown below:

Table 15: Counter Example 1 — Counter 1 setup

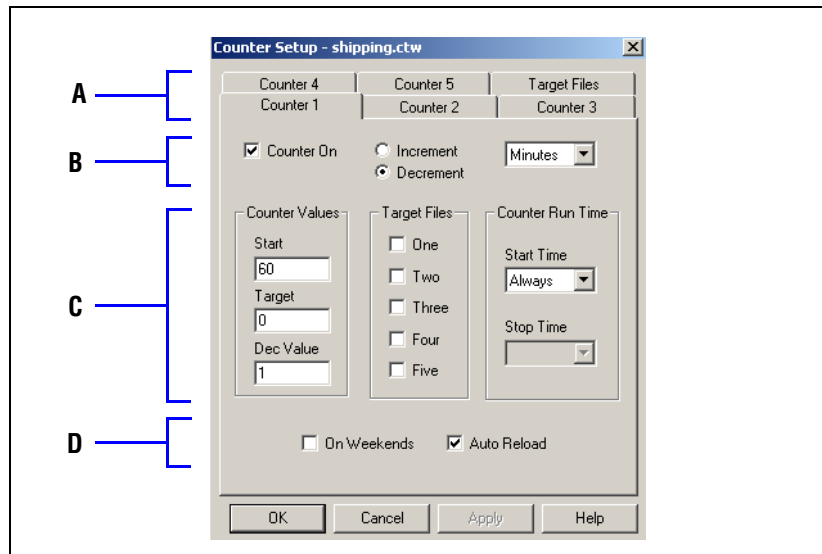

Item	Name	Directions	
A	<i>Counter 1–5</i>	Select <i>Counter 1</i> tab.	
	<i>Target Files</i>	This is where a message is assigned to a target file. One to five messages can be displayed on a sign when counter 1 reaches its target value. (No target files are used in this example.)	
B	<i>Counter On</i>	Make sure this box is checked for this example.	
	<i>Increment Decrement</i>	In this example, select <i>Decrement</i> because we want counter 1 to count down, not up.	
	<i>Minutes Hours Days</i>	Select <i>Minutes</i> because we want counter 1 to count in units of minutes.	
C	<i>Counter Values</i>	<i>Start</i>	Enter <i>60</i> because we want counter 1 to start at 60 minutes and then count down to 0.
		<i>Target</i>	Enter <i>0</i> .
		<i>Dec</i>	Enter <i>1</i> because we want counter 1 to count down 1 minute at a time—60, 59, 58, and so on.
	<i>Target Files</i>	<i>One–Five</i>	This is where you would select which target file messages to display when counter 1 reaches its target value. (No target files are used in this example, so none are checked.)
<i>Counter Run Time</i>	<i>Start Time Stop Time</i>	In this example, <i>Always</i> is selected because we want counter 1 running continuously. Since <i>Always</i> is selected, <i>Stop Time</i> is not available.	
D	<i>On Weekends</i>	Since we do not need our counter running on weekends, this is unchecked.	
	<i>Auto Reload</i>	This box is checked because we want our counter to count down continuously. If this box was not checked, counter 1 would count down from 60 to 0 just once.	

7. Select *OK* after entering the setup information. Double-click the *Shipping* site to open the *Site Editor* window:

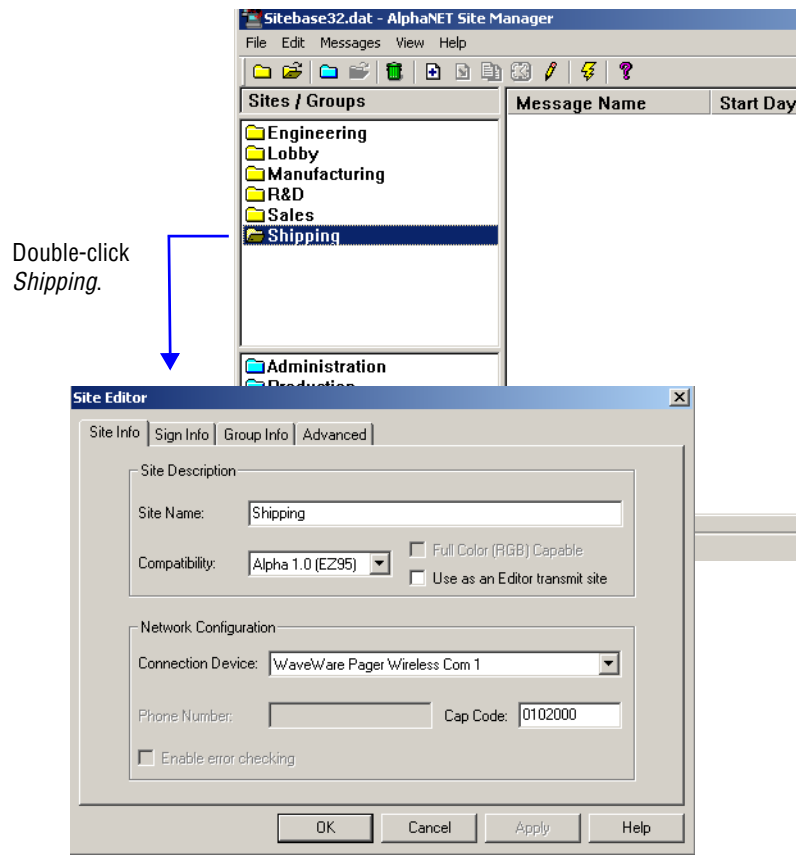

- Next, select the *Sign Info* tab and attach the counter file you just created to the Shipping site:

Deleting a counter file
 If you want to delete a counter file from a sign, click *Counter File*, click *None*, and then click *OK*.

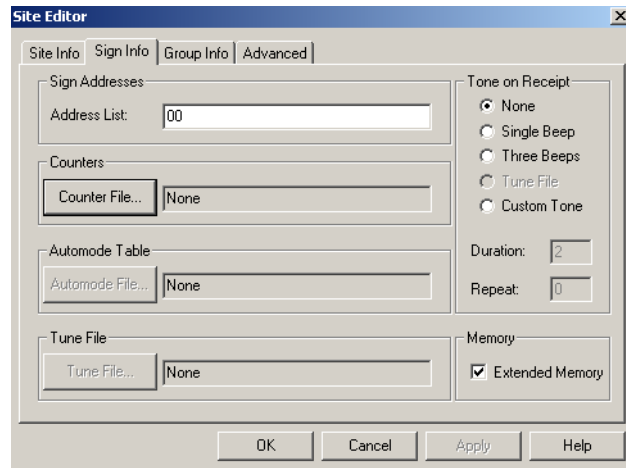

After clicking *Counter File*, select the counter file you just edited (in this case, *shipping.ctw*). Then select *OK*.

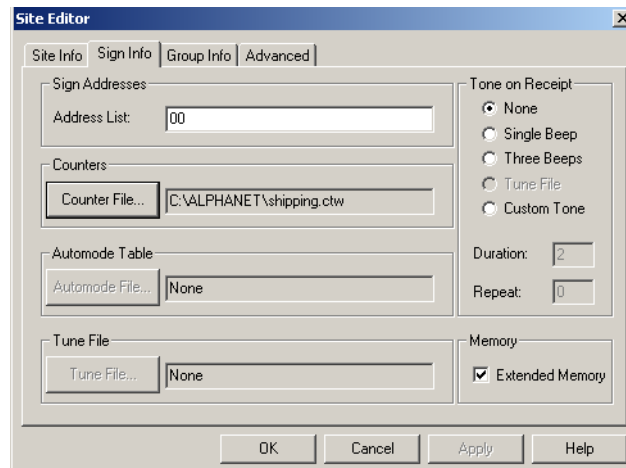
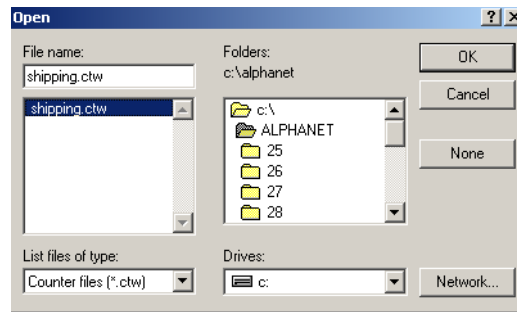

Select *OK*.

9. Add the message that contains counter 1 to the Shipping site:

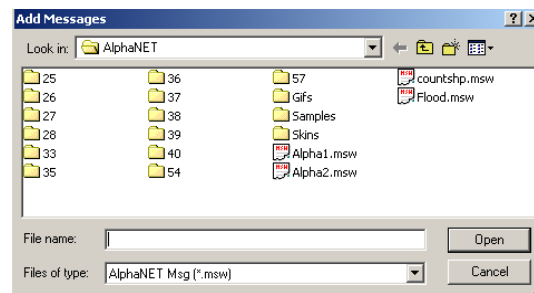
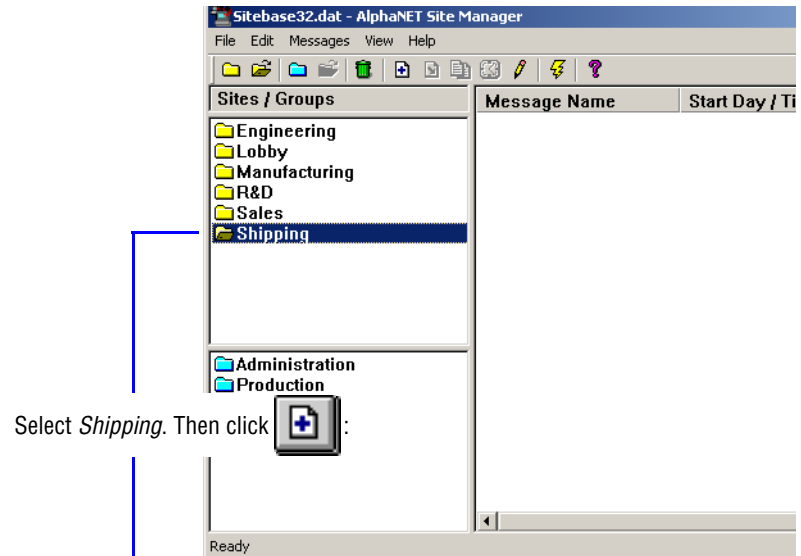

Select the message that contains counter 1 (*countshp.msw*).

Click *OK*.

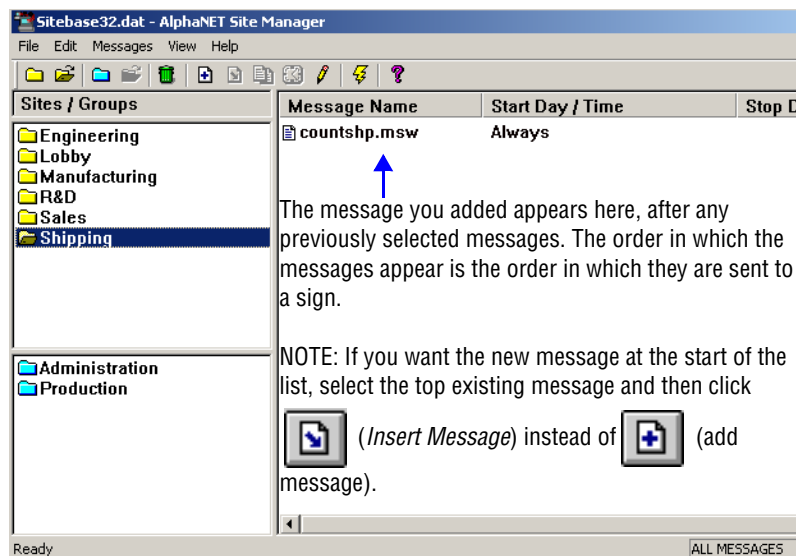

- 10.** Finally, in order to display the message you just added to the Shipping sign, the message must be transmitted. To do this, select the Shipping site and then the transmit icon:

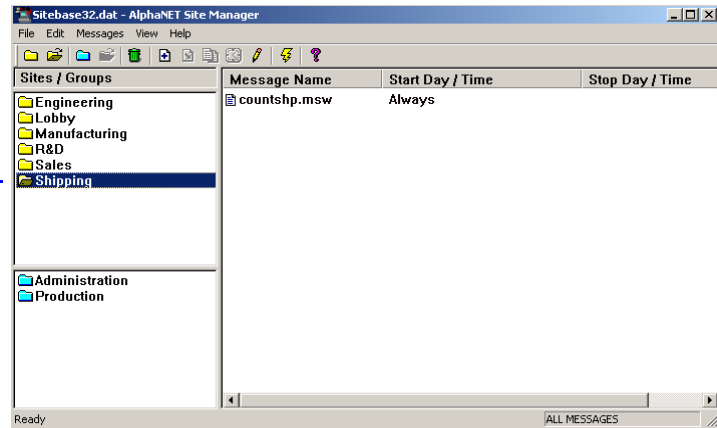

Select *Shipping* because this is the only site to which we want messages sent.



Click the Transmit icon.

Resetting a counter

If you are prompted to reset a sign counter, select *Yes* to reset the counter to its start value.

Otherwise, select *No* to leave the sign's current value intact.

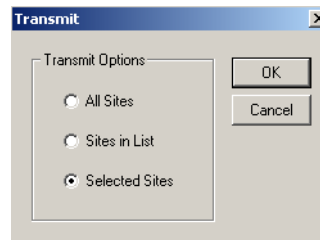

Click *Selected Sites* and then *OK*.

All the messages will be sent to the Shipping site sign.



Example 2 — Using a counter in a message and displaying a target file message

In this example, we will end up with a message on the Manufacturing signs that keeps track of the number of days without an accident.

Also, when 50 days is reached, a message appears on the Manufacturing signs that reads *Another 50 days without an accident!* (this is called a target message.)

NOTE: The Manufacturing signs can still display other messages.



After 50 days, the counter included in the top message (which counts up from 0 to 50) is set up to display the target message below:



1. Open *Message Editor* and create a new message:

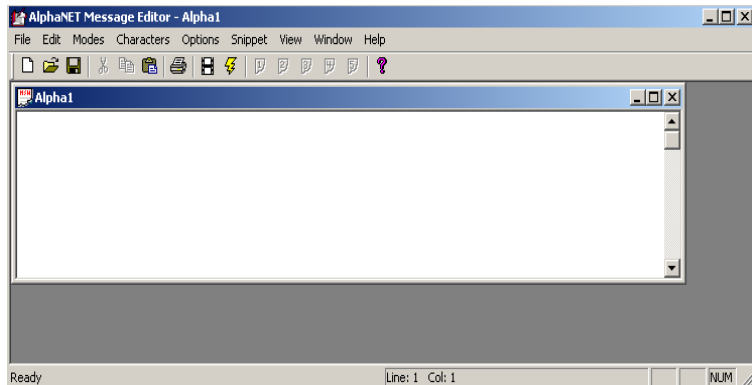

- In the message window, type *Days without an accident:* and a space. Then add a counter to the message by selecting *Options>Counter>Counter 2:*

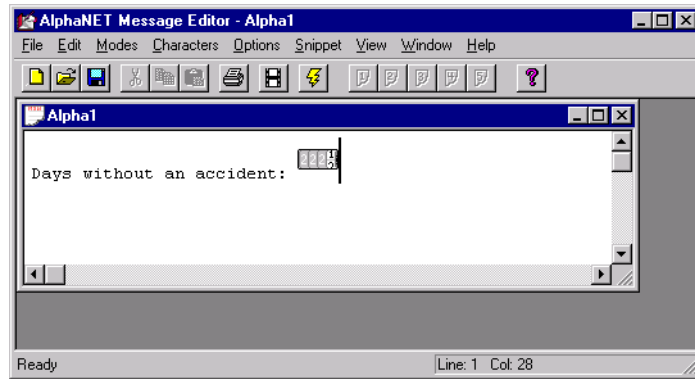
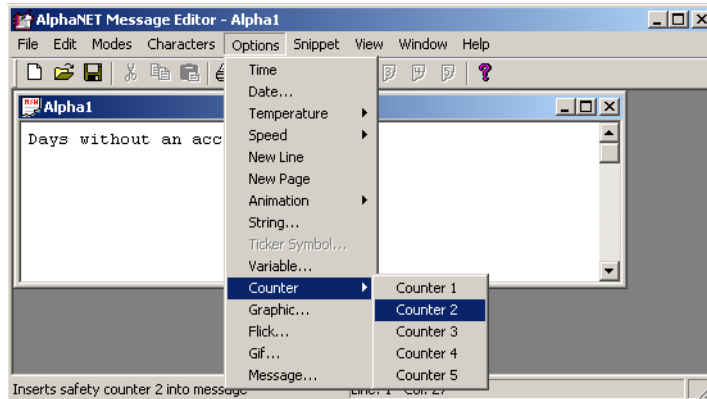

- Save this counter message as *countman.msw* and close the message:

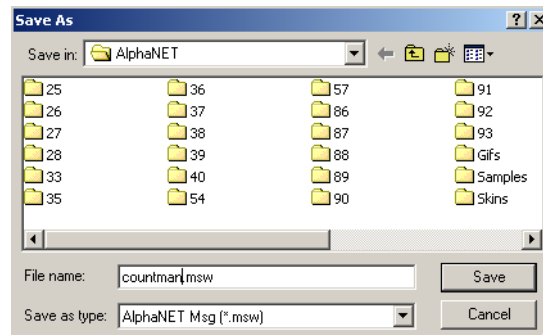

4. Next, create the target message — the message that will appear when counter 2 reaches 50 days. Then save this message as *target1.msw*:

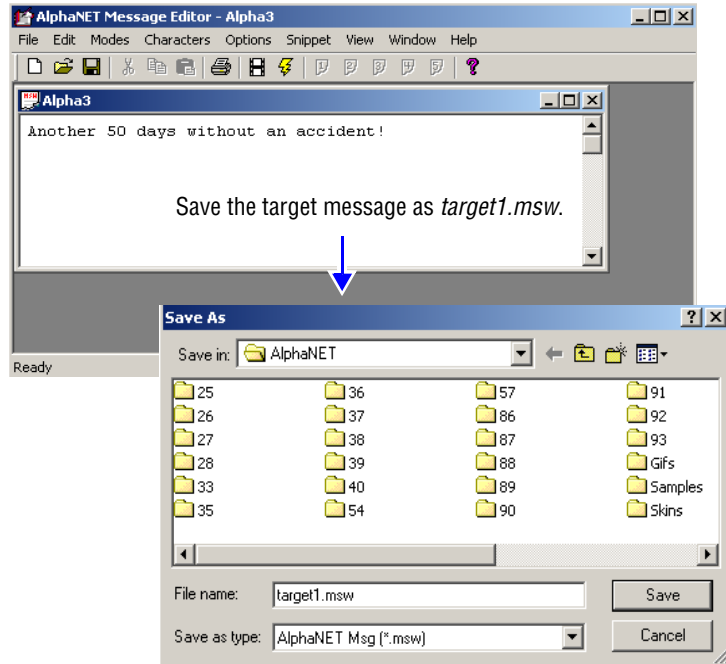

5. Close *Message Editor*. Open *Site Manager* and select *Edit>Counter File*:

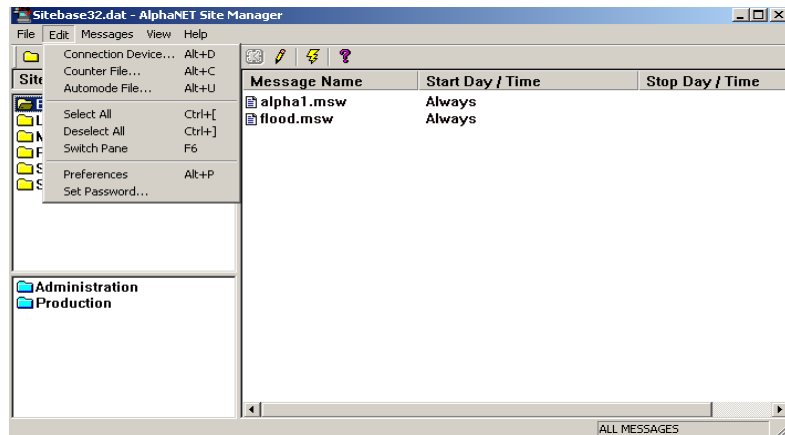

- Next, either open an existing counter file or type a new file name (such as *target.ctw*) and click *Open*:

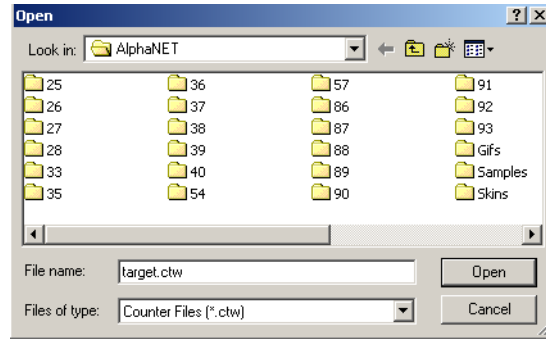

- When the *Counter Setup* window appears, select the *Counter 2* tab and enter the values shown below:

Table 16: Counter Example 2 — Counter 2 setup

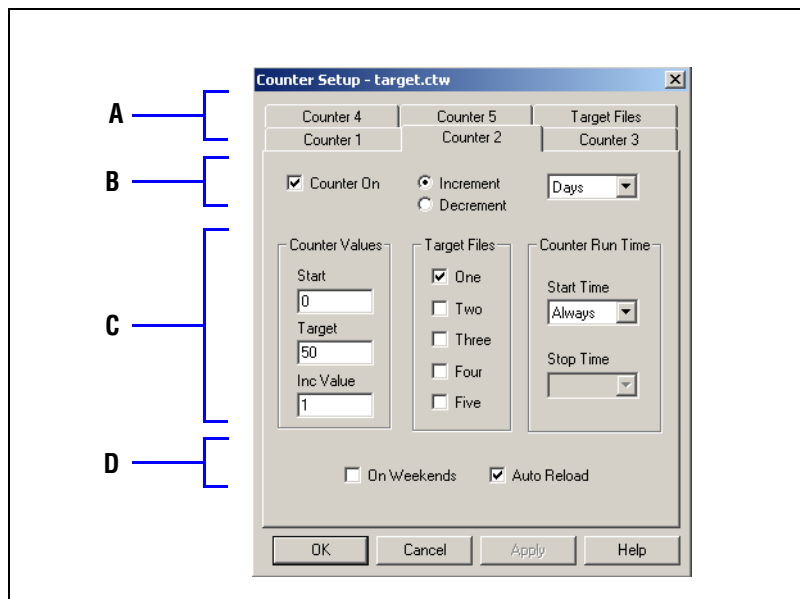

Item	Name	Directions
A	<i>Counter 1–5</i>	Select the <i>Counter 2</i> tab.
	<i>Target Files</i>	This is where a message is assigned to a target file. One to five messages can be displayed on a sign when counter 2 reaches its target value. The largest file runs indefinitely. Send a new message to delete it.
B	<i>Counter On</i>	Make sure this box is checked for this example.
	<i>Increment Decrement</i>	In this example select <i>Increment</i> because we want counter 2 to count up, not down.
	<i>Minutes Hours Days</i>	Select <i>Days</i> because we want counter 2 to count in units of days.

Table 16: Counter Example 2 — Counter 2 setup

C	<i>Counter Values</i>	Start	Enter <i>0</i> because we want counter 2 to start at 0 days and then count up to 50.
		Target	Enter <i>50</i> .
		Inc	Enter <i>1</i> because we want counter 2 to count up 1 day at a time — 1, 2, 3, and so on.
	<i>Target Files</i>	One–Five	Check <i>One</i> . This means that one message will appear on the sign after counter 2 has reached its target value.
D	<i>Counter Run Time</i>	Start Time Stop Time	In this example, <i>Always</i> is selected because we want counter 2 running continuously.
	<i>On Weekends</i>		Since we do not need our counter running on weekends, leave this unchecked.
	<i>Auto Reload</i>		This box is checked because we want our counter to count continuously. If this box was not checked, counter 2 would count up to 50 just once.

8. Next, select the *Target Files* tab and for *Target File 1*, select *Browse* and then the file you created (*target1.msw*):



9. After selecting the target file, click *Open*, and then *OK* to close the *Counter Setup* window. Then double-click the Manufacturing site to access the *Site Editor* window:

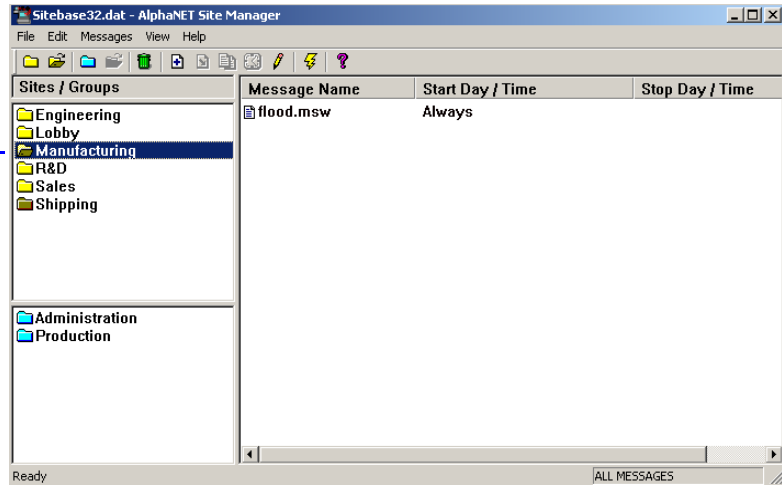

Double-click *Manufacturing*.

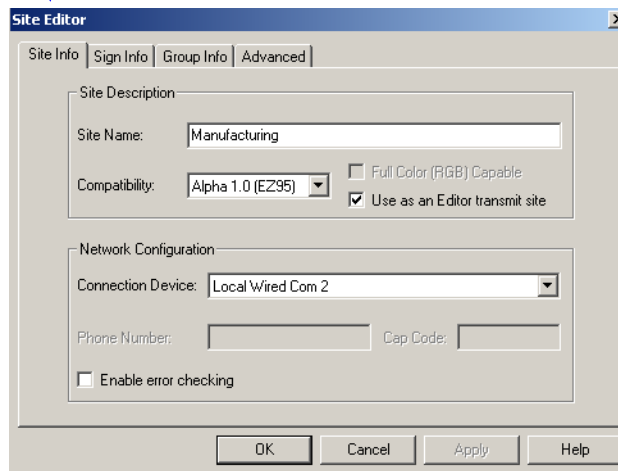

10. Next, select the *Sign Info* tab and attach the counter file you just created to the Manufacturing site:

Deleting a counter file
If you want to delete a counter file from a sign, click *Counter File*, click *None*, and then click *OK*.

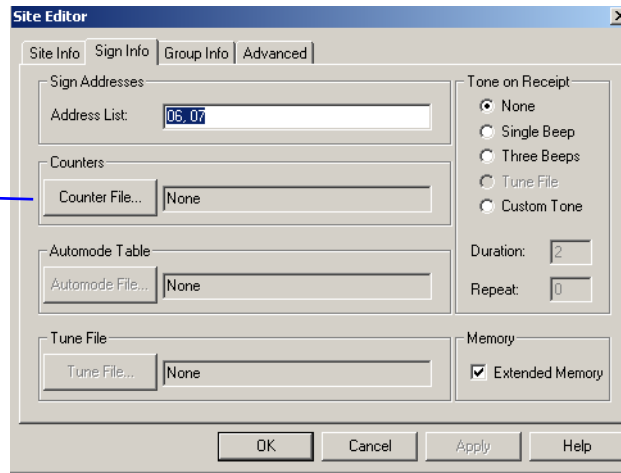

After clicking *Counter File*, select the counter file you just edited (in this case, *target.ctw*.) Then select *OK*.

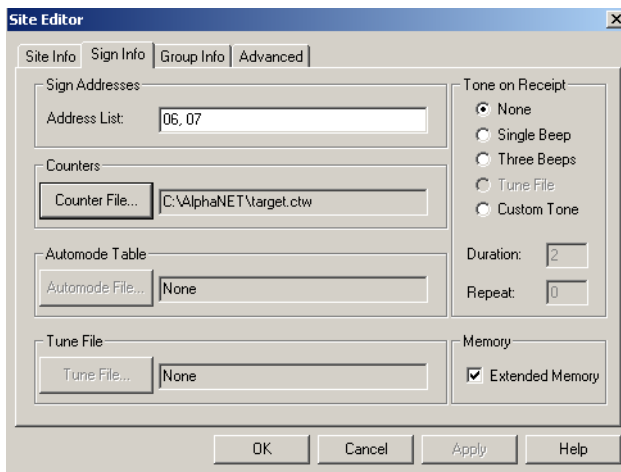
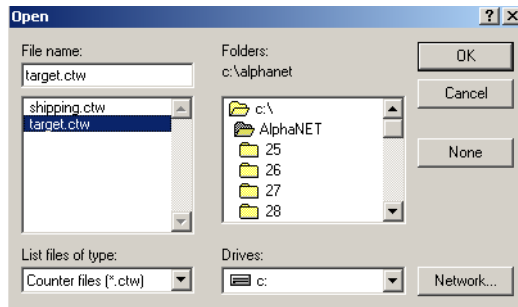

Select *OK*.

11. Add the message that contains counter 2 to the Manufacturing site:

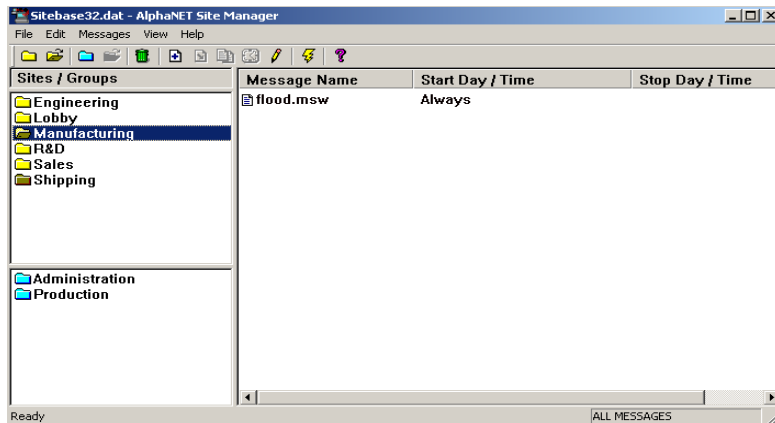

Select *Manufacturing*. Then select  :

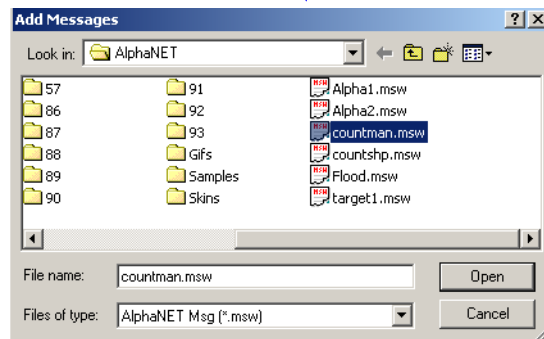

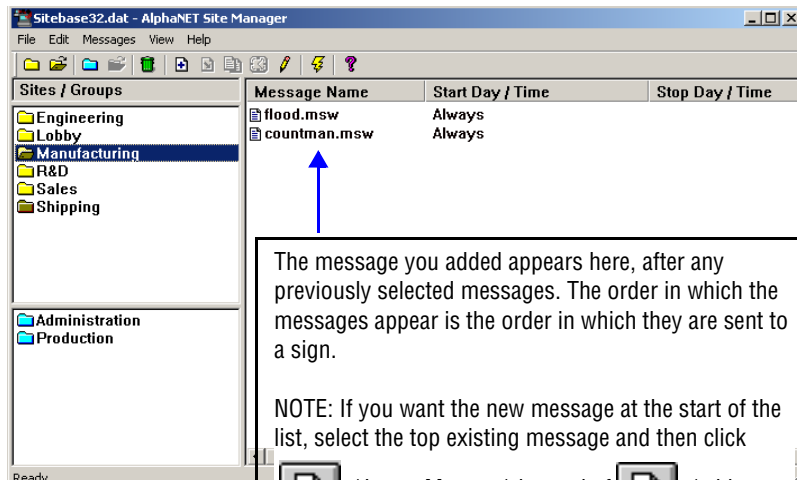

Select the message that contains counter 2 (*countman.msw*).

Click *Open*.



The message you added appears here, after any previously selected messages. The order in which the messages appear is the order in which they are sent to a sign.

NOTE: If you want the new message at the start of the list, select the top existing message and then click

 (*Insert Message*) instead of  (add message).

12. Finally, in order to display the message you just added, it must be transmitted to the Manufacturing signs. To do this, select the Manufacturing site and then the Transmit icon:

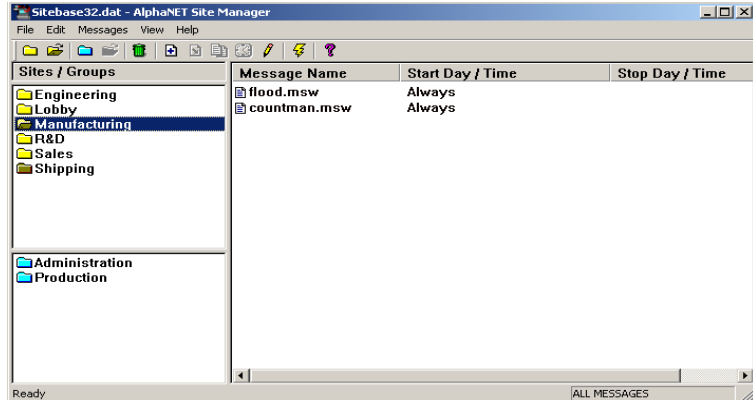

Select *Manufacturing* because this is the only site to which we want messages sent.



Click the Transmit icon.

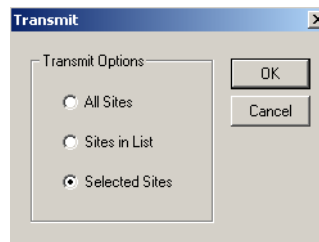

Click *Selected Sites* and then *OK*.

Resetting a counter

If you are prompted to reset a sign counter, select *Yes* to reset the counter to its start value.

Otherwise, select *No* to leave the sign's current value intact.

All the messages will be sent to the Manufacturing site signs.

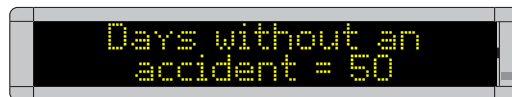

After 50 days, the counter included in the top message (which counts up from 0 to 50) will display the target message below:

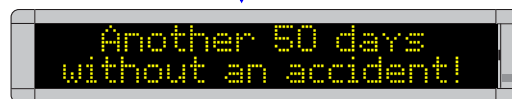

Example 3 — Using a counter to display just a target message

HINT
This example is nearly identical to Example 2.
In Example 2, the counter was displayed as well as a target message.
In Example 3, only the target message will be displayed. The counter will just count.

In this example, we will use one of the five counters (in this case, counter 3) to display the message *Another 100 hours of safe operation!* When counter 3 reaches 100 hours, the message will appear on all the signs in the Engineering site. (This site was created in the previous section “How to change a sign’s serial address” on page 15.)

NOTE: The Engineering signs can still display other messages.

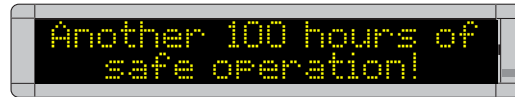

1. Open *Message Editor* and create a new message:

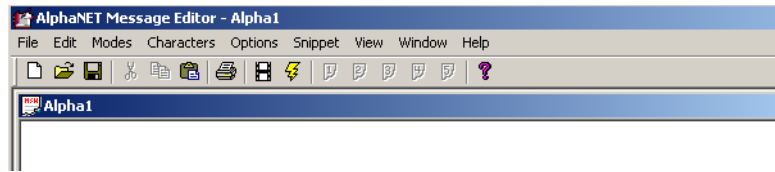

2. Next, create the target message — the message that will appear when counter 3 reaches 100 hours. Then save this message as *target2.msw*:

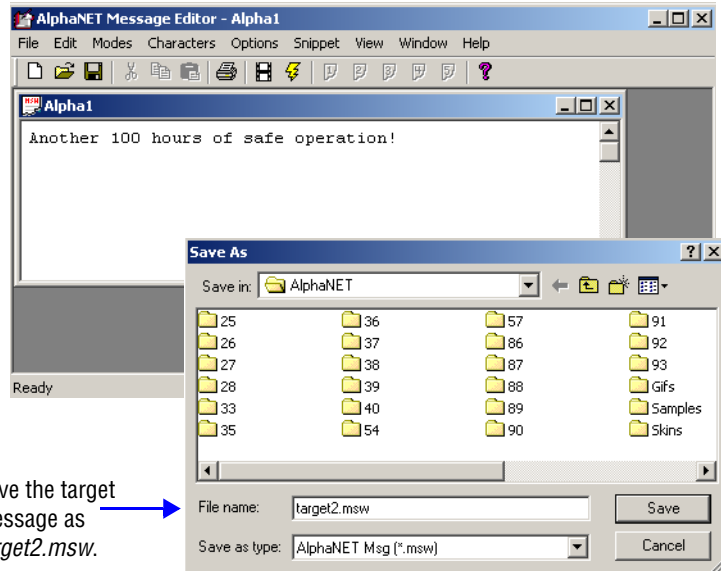

3. After saving the target message, close *Message Editor*. Open *Site Manager* and select *Edit>Counter File*:



4. Next, either open an existing counter file (like the default file shown below) or type a new file name (like *engineer.ctw*):

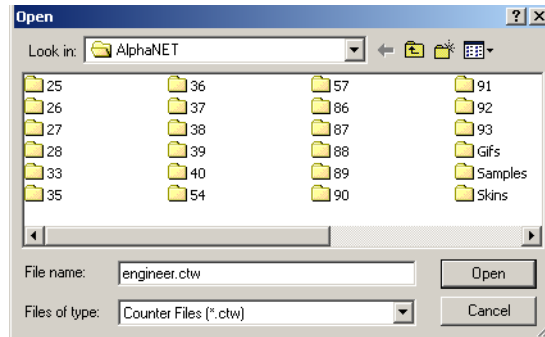

5. When the *Counter Setup* window appears, select the *Counter 3* tab and enter the values shown below:

Table 17: Counter Example 3 — Counter 3 setup

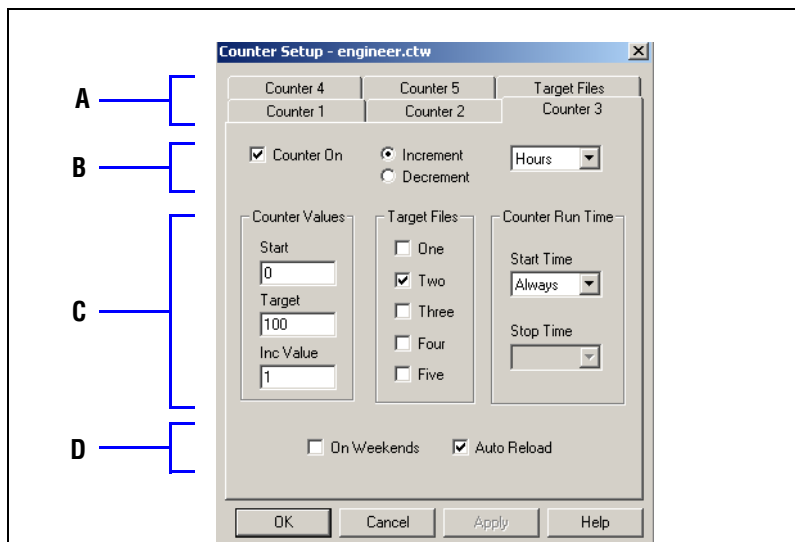

Item	Name	Directions
A	<i>Counter 1–5</i>	Select the <i>Counter 3</i> tab.
	<i>Target Files</i>	This is where a message is assigned to a target file. One to five messages can be displayed on a sign when counter 3 reaches its target value. The largest file runs indefinitely. Send a new message to delete it.
B	<i>Counter On</i>	Make sure this box is checked for this example.
	<i>Increment Decrement</i>	In this example, select <i>Increment</i> because we want counter 3 to count up, not down.
	<i>Minutes Hours Days</i>	Select <i>Hours</i> because we want counter 3 to count in units of hours.

Table 17: Counter Example 3 — Counter 3 setup

C	<i>Counter Values</i>	<i>Start</i>	Enter 0 because we want counter 3 to start at 0 hours and then count up to 100.
		<i>Target</i>	Enter 100.
		<i>Inc</i>	Enter 1 because we want counter 3 to count up 1 hour at a time—1, 2, 3, and so on.
	<i>Target Files</i>	<i>One-Five</i>	Check <i>Two</i> . This means that one message will appear on the sign after counter 3 has reached its target value.
	<i>Counter Run Time</i>	<i>Start Time</i> <i>Stop Time</i>	In this example, <i>Always</i> is selected because we want counter 3 running continuously.
D	<i>On Weekends</i>		Since we do not need our counter running on weekends, leave this unchecked.
	<i>Auto Reload</i>		This box is checked because we want our counter to count down continuously. If this box was not checked, counter 3 would count up to 100 just once.

- Next, select *Target Files*. For *Target File 1*, select *Browse* and then select the file you created called *target2.msw*:

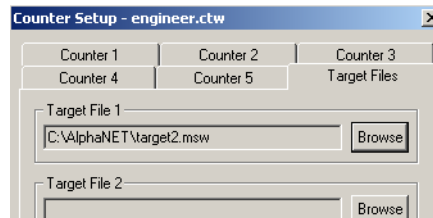

- After selecting the target file, click *OK*. Then double-click the *Engineering* site to access the *Site Editor* window:

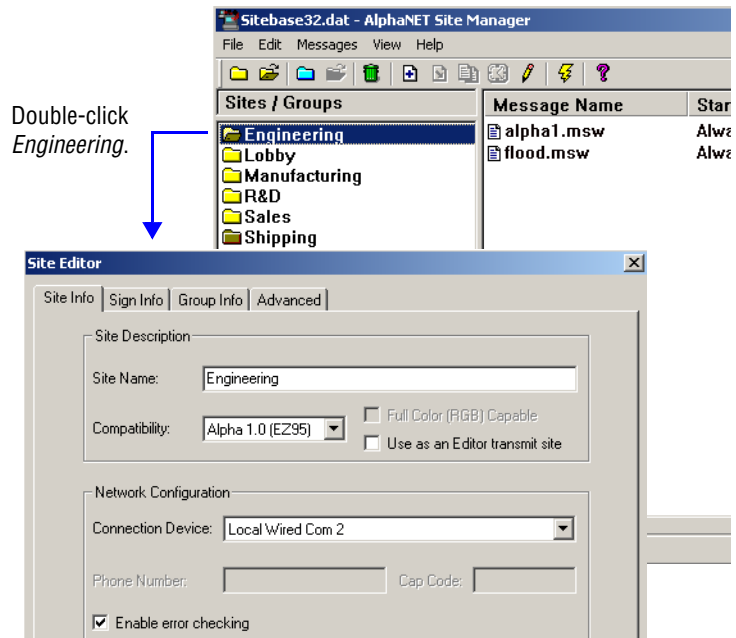

- Next, select *Sign Info* and attach the counter file you just created to the Engineering site:

Deleting a counter file
If you want to delete a counter file from a sign, click *Counter File*, click *None*, and then click *OK*.

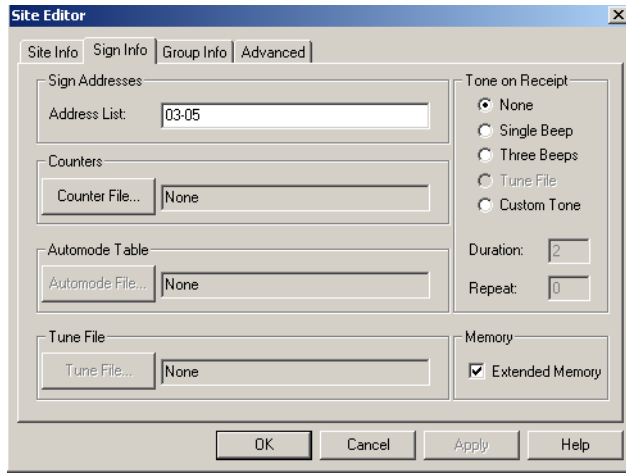

After clicking *Counter File*, select the counter file you just edited (in this case, *engineer.ctw*). Then select *OK*.

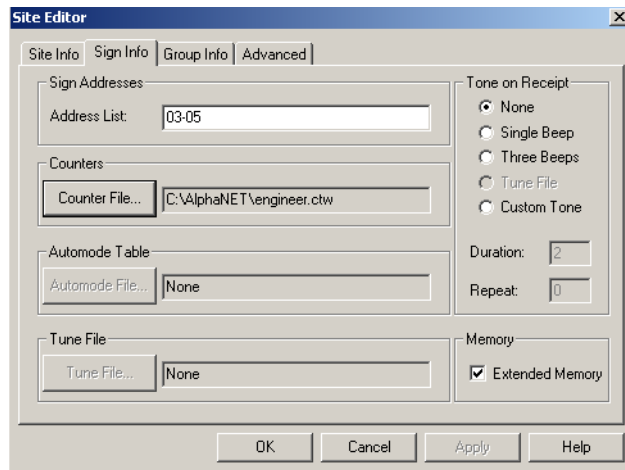
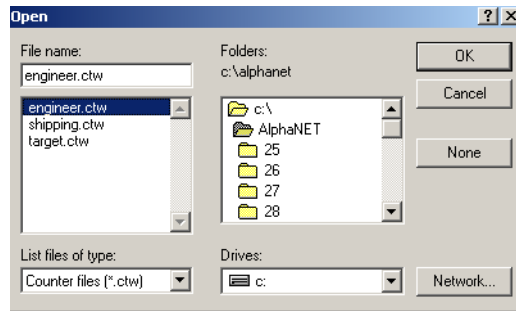

Select *OK*.

How to use real-time data in a message

String Variables + ActiveX® = real-time data

Data from external sources (for example, Microsoft® Excel, Access, and Visual Basic® software) can be displayed on Alpha® signs by using two features included in AlphaNET™ 3.0 software:

- String variables
- Alpha® String Update Control (an ActiveX® component)

A variable in the AlphaNET™ 3.0 software represents real-time data that can change (for example, temperature or production rates, date, or time). Variables can be put into messages.

The value of a variable can be changed using the Alpha® String Update Control. Because this is an ActiveX® control, it can be used with a variety of ActiveX®-compatible applications, such as Microsoft® Excel, Access, and Visual Basic® software.

NOTE: Besides using the Alpha® String Update Control, you can also write your own application to update variables. For more information, see the **Alpha® Sign Communications Protocol** manual.

HINT

The AlphaNET™ 3.0 software CD ROM contains examples on using the Alpha® String Update Control.

Real-time data example

Create sign memory configurations using Site Manager

1. In *Site Manager*, double-click the site for the sign which will use string variables. Then click the *Advanced* tab.

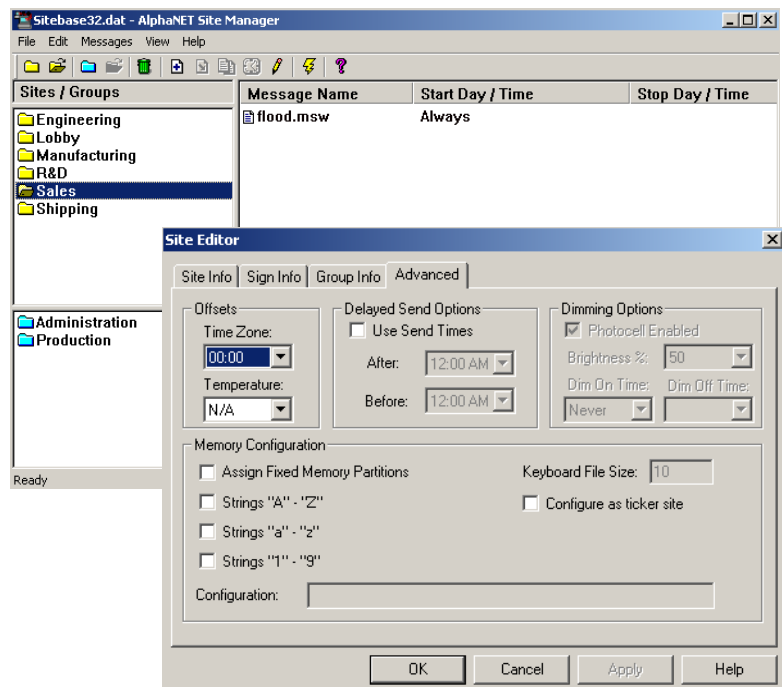

2. Create a sign memory configuration by checking either:

- *Assign Fixed Memory Partitions* — Check this to assign your own sign memory configuration in the *Configuration* box. (For detailed information, see the Memory Configuration examples in “Appendix G: Protocol Examples” of the **Alpha® Sign Communications Protocol** manual.)
- *Strings “A” - “Z”, Strings “a” - “z”, Strings “1” - “9”* — Check one, two, or all three of these to create a sign memory configuration in the *Configuration* box. For example, checking *Strings “A” - “Z”* would set up 26 string file names “A” through “Z”. These files could then be used by the Alpha® String Update Control. (Checking *Strings “a” - “z”* would set up an additional 26 strings, and checking *Strings “1” - “9”* would add another 9 strings.)

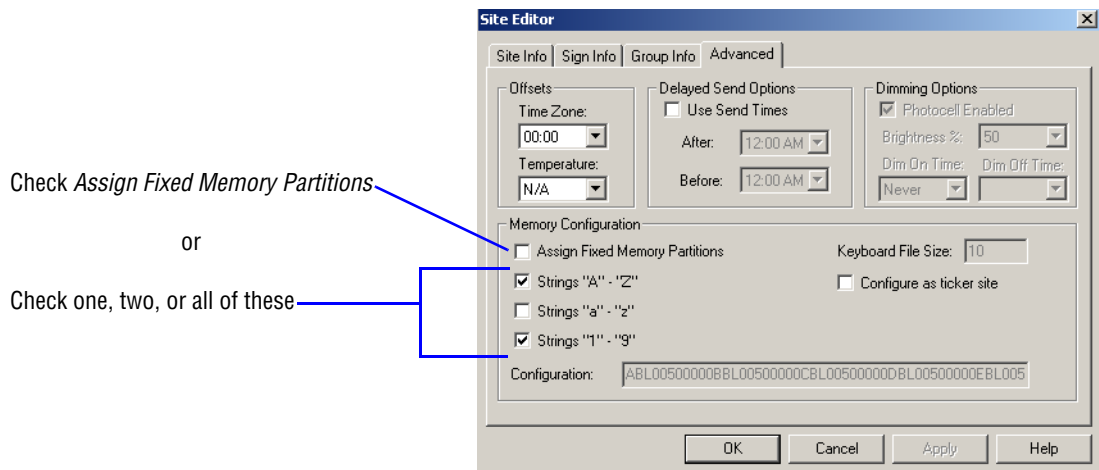

Create a message with a string variable using Message Editor

3. In *Message Editor*, create a new message by selecting *File>New*:

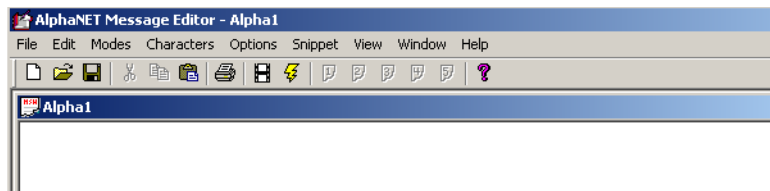

4. Type *Today's sales total*:

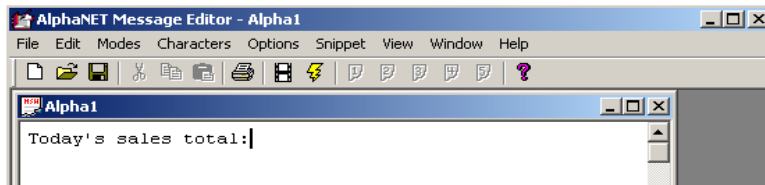

5. Select *Options>String* to insert a string variable into the message:

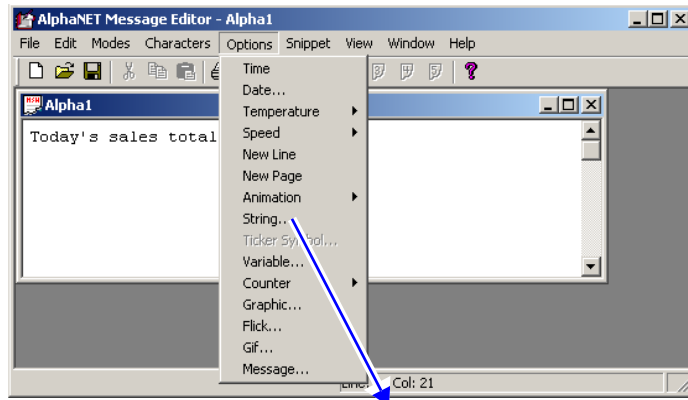

The string label value is determined by what you selected in step 2. For example, if you selected *Strings "1" - "9"*, then type a number from 1 to 9.

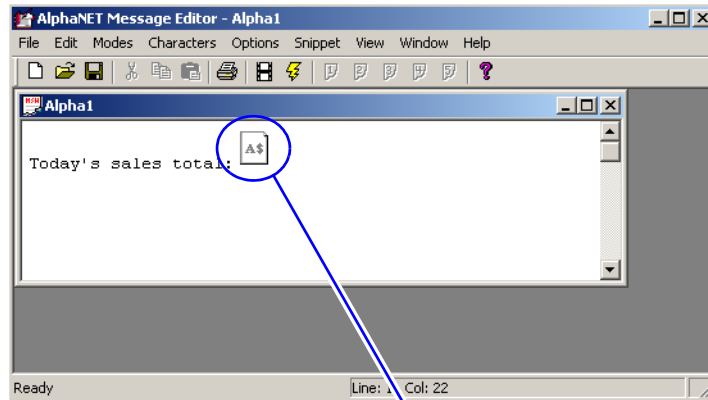
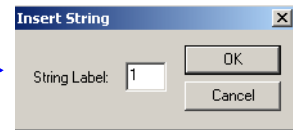

The string variable icon.

Update the string variable using the ActiveX® control

6. Use the Alpha® String Update Control (the ActiveX® component of AlphaNET™ 3.0 software) to update the message's string variable.

Following is a description of the available methods and properties of this ActiveX® control:

Table 18: Alpha® String Update Control Methods & Properties

METHODS		
Initialize	Syntax:	<i>AlphaStringUpdateCtrl.Initialize</i>
	Parameters:	none
	Remarks:	Method must be called prior to calling any other method of this control. This method opens a COM port or creates a socket connection to the display.
UpdateString	Syntax:	<i>AlphaStringUpdateCtrl.UpdateString("String Label", Value, Color, Flash)</i>
	Parameters:	<ul style="list-style-type: none"> • <i>String Label</i> — String. One character only. (In the previous example, the <i>String Label</i> is 1.) • <i>Value</i> — String. This is the value to be passed and displayed. • <i>Color</i> — Integer. 1 = Red, 2 = Green, 3 = Amber. • <i>Flash</i> — Byte. 0 = off, 1 = on.
	Remarks:	This method will pass any value to the designated string. The <i>Color</i> parameter will override any color definition set by the message itself. The <i>Flash</i> parameter will only work in the <i>Hold</i> mode.

PROPERTIES		
<i>ConnectMode</i>	Type:	Byte
	Values:	0 = Serial connection, 1 = TCP/IP connection
<i>NetworkAddress</i>	Type:	String
	Values:	TCP/IP address of the network adapter. (Only applicable to a TCP/IP connection.)
<i>NetworkPort</i>	Type:	Integer
	Values:	3001 (default)
<i>SerialBaudRate</i>	Type:	Integer
	Values:	110, 300, 600, 1200, 4800, 9600, 14400, 19200, 28800, 38400, 56000, 115200, 128000, 256000
<i>SerialComPort</i>	Type:	Byte
	Values:	1 through 16
<i>SerialDataBits</i>	Type:	Byte
	Values:	4 through 8
<i>SerialParity:</i>	Type:	String
	Values:	None, Even, Odd, Mark, Space
<i>SerialStopBits</i>	Type:	Byte
	Values:	1 or 2
<i>Serial Address</i>	Type:	Integer (use 2 digits)
	Values:	00 (default)

How to create and use a custom automode sequence

The message mode called *Automode* is the default mode used if no other mode is selected in a message. It displays the message with all the other modes provided with AlphaNET™ 3.0 software. (For descriptions of the modes, see “Appendix B — Modes available on signs” on page 137.)

A custom automode sequence can be created for each sign site.

You can set what modes automode will use by doing the following:

Creating or editing an Automode sequence

1. In *Site Manager*, choose *Edit>Automode File*:

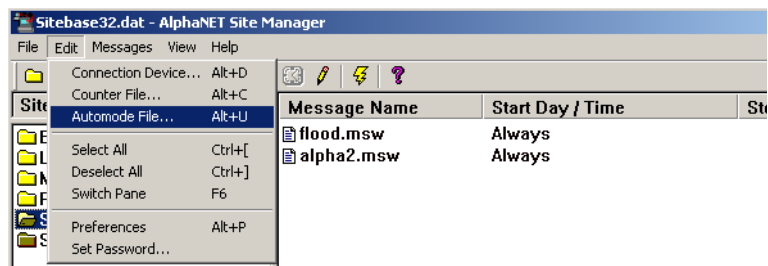

2. Accept the name of *default.aut* for the file, choose an existing file if there is one, or type in a different name for a new file to use. Then click *Open*.

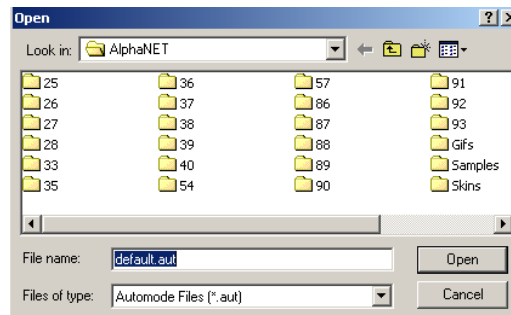

3. Click *Add*. Then select the *Interlock > OK* to add the Interlock mode to our custom automode sequence:

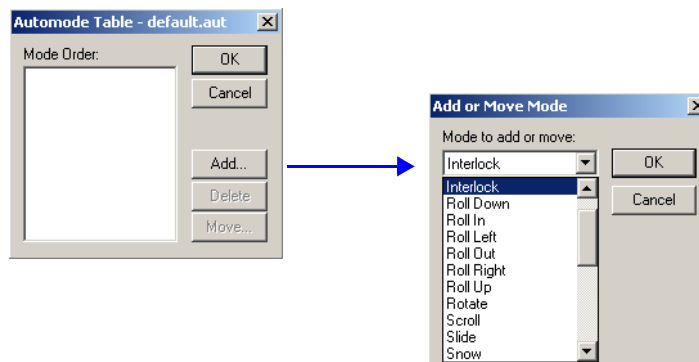

4. To add another mode to our custom automode sequence, click *Add* again. Then select another mode and click *OK*.

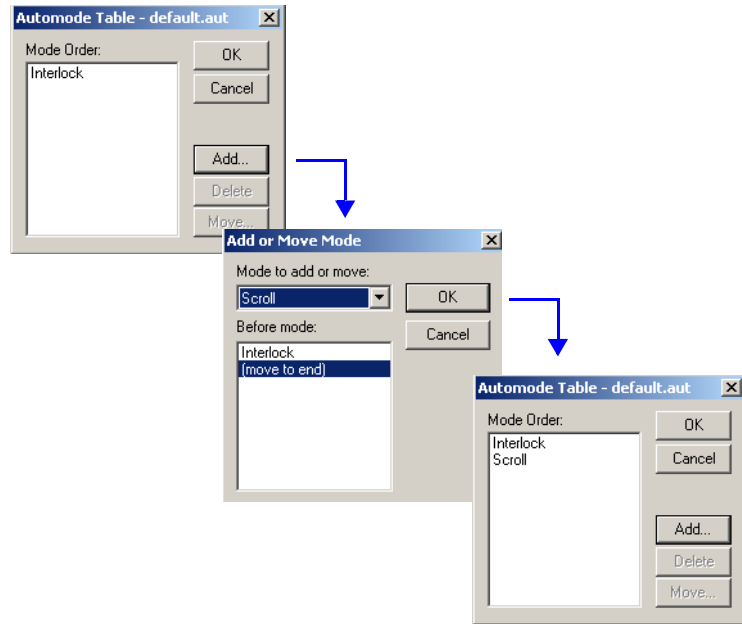

NOTE: The order of the modes can be changed using *Move*. Modes can also be added or deleted using *Add* and *Delete*.

Using a custom Automode sequence

1. Using *Site Editor*, double-click the site that is to have the custom automode. Select the *Site Info* tab and choose *Alpha 2.0* for *Compatibility*.

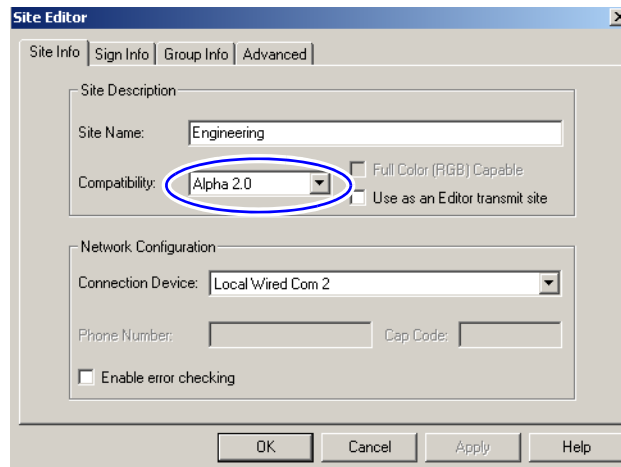

2. Select the *Sign Info* tab. Then click *Automode File* and select a custom automode file:

NOTE
To revert back to the default automode setting, click *Automode File*, click *None*, and then click *OK*.

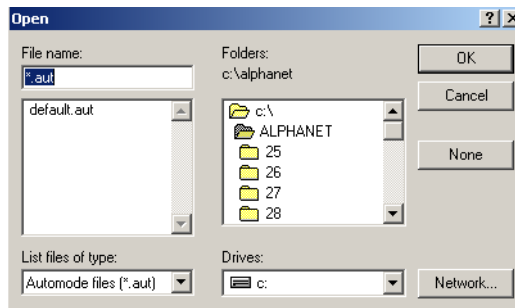
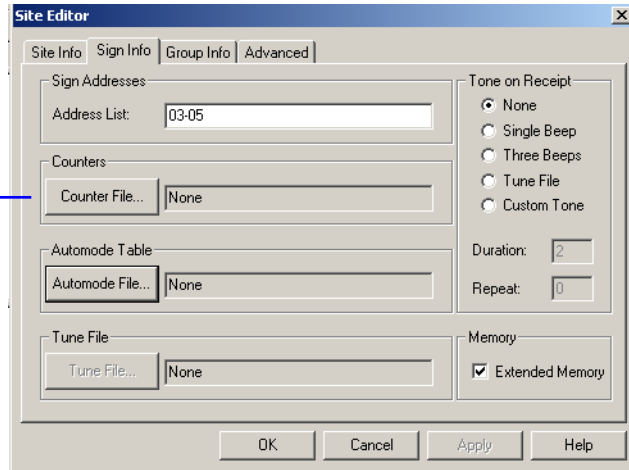

Messages sent to this site will now use this custom automode.

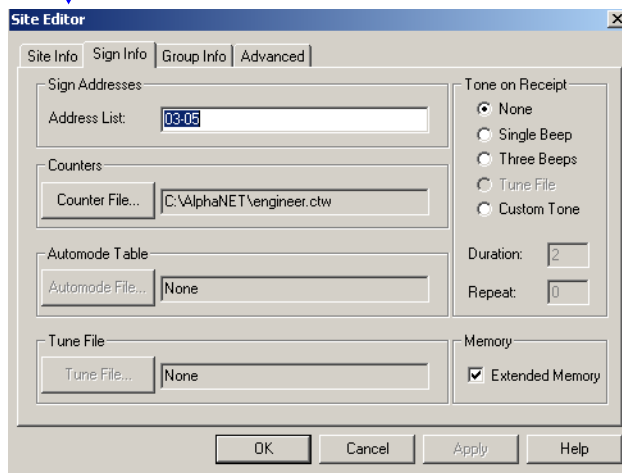

Select *OK*.

THIS PAGE INTENTIONALLY BLANK

4

Reference



Message Editor

Message Editor is used to create messages for signs. Text, graphics, and animations (or flicks) can be used in messages. See Chapter 3 for detailed instructions on using *Message Editor*.

The screenshot shows the AlphaNET Message Editor window with the following components and their corresponding menu options:

- File Menu:** New (Ctrl+N), Open... (Ctrl+O), Close, Save (Ctrl+S), Save As..., Print... (Ctrl+P), Print Preview, Print Setup..., Simulate (Ctrl+E), Transmit... (Alt+T), Recent files (1 target2.msw, 2 target1.msw, 3 countman.msw, 4 countshp.msw), Exit.
- Edit Menu:** Undo (Ctrl+Z), Cut (Ctrl+X), Copy (Ctrl+C), Paste (Ctrl+V), Find..., Find Again Down (F3), Find Again Up (Shift+F3), Replace... (F4), Spell Check (F7), Customize... (F10), Set Password...
- Modes Menu:** Automode, Flash, Hold, Interlock, Roll, Rotate, Scroll, Slide, Snow, Sparkle, Spray, Starburst, Switch, Twinkle, Wipe, Cycle Color, Clock, Explode.
- Toolbar:** Includes icons for New, Open, Save, Print, Simulate, Transmit, Undo, Cut, Copy, Paste, Find, Replace, Spell Check, and Help.
- Status Bar:** Shows 'Ready' and 'Line: 1 Col: 26'.
- Characters Menu:** 15/16 Row Normal, 15/16 Row Fancy, Ten Row, Seven Row Normal (checked), Seven Row Fancy, Five Row, Condensed, Custom, Color, Normal (checked), Wide, Double Wide, Flashing, Double High, True Descenders, Fixed Width, Shadow.
- Options Menu:** Time, Date..., Temperature, Speed, New Line, New Page, Animation, String..., Ticker Symbol..., Variable..., Counter, Graphic..., Flick..., Gif..., Message...
- Snippet Menu:** Capture... (Ctrl+A), Snippet 1 (Alt+1), Snippet 2 (Alt+2), Snippet 3 (Alt+3), Snippet 4 (Alt+4), Snippet 5 (Alt+5).
- View Menu:** Toolbar (checked), Status Bar (checked), Codes (F11).
- Window Menu:** Cascade, Tile, Arrange Icons, 1 Alpha1 (checked).

Table 19: Message Editor

Menu Item		Description
<i>File</i>	<i>New</i>	Opens a new message window.
	<i>Open...</i>	Opens an existing message file.
	<i>Close</i>	Closes the message window.
	<i>Save</i>	Saves a message.
	<i>Save As...</i>	Saves the current message under a different name.
	<i>Print...</i>	Prints a message.
	<i>Print Preview</i>	Previews a message (in print form).
	<i>Print Setup...</i>	Change printers, page size, and so on.
	<i>Simulate</i>	Previews a message (in display form).
	<i>Transmit...</i>	<p>Sends a message to either every site or some sites:</p> <p style="text-align: center;">This sends a message to every site.</p>  <p style="text-align: center;">This sends a message to only those sites that have been specified in <i>Message Editor</i>. See “R & D setup (1 of 4): Site Editor (Site Info) window” on page 30.</p>
<p>1 File name 1 2 File name 2 3 File name 3 4 File name 4</p>	A list of recent message file names which can be selected and opened.	
<i>Exit</i>	Quits <i>Message Editor</i> .	
<i>Edit</i>	<i>Undo</i>	If highlighted, reverses the last action performed.
	<i>Cut</i>	Deletes selected text or graphics from a message and places it on the clipboard.
	<i>Copy</i>	Copies selected text or graphics from a message and places it on the clipboard.
	<i>Paste</i>	Places text or graphics on the clipboard at the current cursor position in a message.
	<i>Find...</i>	Locates a word or phrase in a message.
	<i>Find Again Down...</i>	
	<i>Find Again Up...</i>	
	<i>Replace...</i>	Replaces text in a message with text of your choice.
<i>Spell Check</i>	Verifies the text in a message is spelled correctly.	

Table 19: Message Editor

Menu Item	Description
<p><i>Edit</i> (continued)</p> <p><i>Customize...</i></p>	<p>Sets the availability of <i>Message Editor</i> drop-down menu options, whether text or pictures will appear for modes, characters, and options, and the number of space to insert for a tab setting.</p> <p>The type of sign selected here dictates the options available in the drop-down menus.</p> 
<p><i>Set Password...</i></p>	<p>Allows you to password-protect <i>Message Editor</i>.</p>  <p>Type a password in the <i>New Password</i> and <i>Verify</i> lines, then click <i>OK</i>.</p> <p>You will be prompted for this password the next time you open <i>Message Editor</i>.</p>

<p>Modes</p> <p>(For more information, see “Using modes to change the look of a message” on page 51.)</p> <p>NOTE: Some modes may not be available on a sign. See “Appendix B — Modes available on signs” on page 137.</p>	<p><i>Automode</i></p>	<p>The default mode. If no other mode is selected, a message will appear in automode. Automode cycles through a list of all other modes. The list of modes and their sequence in the automode cycle can be customized as needed.</p>
	<p><i>Flash</i></p>	<p>Flashes message.</p>
	<p><i>Hold</i></p>	<p>Holds message for several seconds.</p>
	<p><i>Interlock</i></p>	<p>Alternating rows of dots enter from each end of a sign and interlock a message into the center of the sign.</p>
	<p><i>Roll</i></p>	<p>Rolls the previous message off the sign while rolling the new message on.</p>
	<p><i>Rotate</i></p>	<p>Rotates a message from the right to the left horizontally across a sign.</p>
	<p><i>Scroll</i></p>	<p>Moves a message up one line at a time. The previous message is pushed up.</p>
	<p><i>Slide</i></p>	<p>A message moves onto the sign from right to left, one character at a time.</p>
	<p><i>Snow</i></p>	<p>The new message snows over and erases the current message.</p>
	<p><i>Sparkle</i></p>	<p>The new message sparkles onto the sign over the current message.</p>
	<p><i>Spray</i></p>	<p>A message sprays across the sign from right to left, one character at a time.</p>
	<p><i>Starburst</i></p>	<p>Random starbursts explode a message onto a sign.</p>
	<p><i>Switch</i></p>	<p>Alternating characters of a message slide off a sign in different directions (first character slides up, the next down, and so on). New characters appear in the same manner.</p>
	<p><i>Twinkle</i></p>	<p>A message appears with a twinkling effect.</p>
<p><i>Wipe</i></p>	<p>The new message is wiped over the current message.</p>	

Table 19: Message Editor

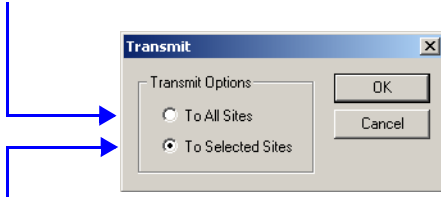
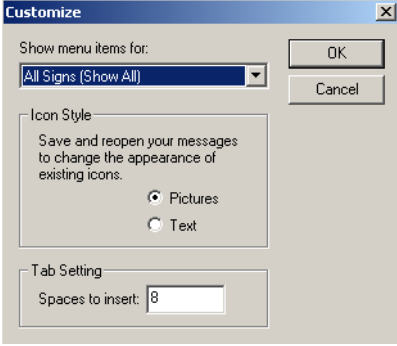
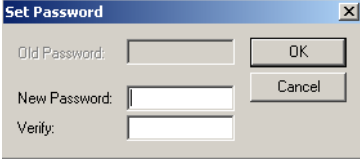
Menu Item	Description
<i>Cycle Color</i>	Cascades colors through the message from the bottom up.
<i>Clock</i>	Wipes information on and off the sign as if a second hand were sweeping around it.
<i>Explode</i>	Rolls information from the center of the sign and out in all four directions at once.

<p>Characters</p> <p>(For more information, see “Using characters to change the look of a message” on page 54.)</p> <p>NOTE: Some characters may not be available on a sign. See “Appendix C — Character fonts and colors available on signs” on page 139.</p>	<i>15/16 Row Normal</i>	
	<i>15/16 Row Fancy</i>	
	<i>Ten Row</i>	The height of text in rows. For example, <i>Seven Row Normal</i> (or <i>Fancy</i>) text is 7 rows tall on a sign.
	<i>Seven Row Normal</i>	
	<i>Seven Row Fancy</i>	See “Text comes in four basic sizes” on page 148.
	<i>Five Row</i>	
	<i>Condensed</i>	Allows selection of <i>15/16 Row</i> , <i>Ten Row</i> , <i>Seven Row</i> , or <i>Five Row</i> in a condensed format.
	<i>Custom</i>	Allows selection of <i>15/16 Row</i> , <i>Ten Row</i> , <i>Seven Row</i> , or <i>Five Row</i> in a customized format. Custom fonts must be installed in the sign’s memory outside of AlphaNET™ 3.0 software.
	<i>Color</i>	Allows selection of multiple colors if you have a multicolor sign. If no color is selected, then autocolour is set. In this case, the available colors are randomly displayed.
	<i>Normal</i>	The default setting for characters.
	<i>Wide</i>	Text is displayed in bold characters.
	<i>Double Wide</i>	Text is displayed in very bold characters.
	<i>Flashing</i>	Allows individual or many characters to flash on and off.
	<i>Double High</i>	Doubles the selected character height
	<i>True Descenders</i>	When checked, the lower (or descender) part of letters such as j, g, and q are displayed on a sign.
<i>Fixed Width</i>	When checked, each character takes up a fixed width like typewriter text. Otherwise, text is displayed proportionally with varying widths.	
<i>Shadow</i>	Allows selection of the shadow color for the message characters.	

Table 19: Message Editor

Menu Item	Description
<i>Time</i>	Inserts the time into a message. NOTE: The time is based on the time stored in your computer. If your computer's clock is incorrect, then the time displayed on a sign will also be incorrect.
<i>Date...</i> Options Some options may not be available on a sign. See "Appendix D — Display Options available on signs" on page 140.	Inserts the date into a message. A number of formats are available: 
<i>Temperature</i>	Inserts the current temperature in either Fahrenheit or Celsius into a message. NOTE: This option is only available on the 790i, Solar™, and AlphaEclipse™ outdoor signs.
<i>Speed</i>	The <i>Speed</i> menu item displays 5 speeds and a <i>No Hold</i> option. Each speed determines how fast messages are displayed on a sign and then replaced by the next message. Speed 1 is the slowest and Speed 5 is the fastest. Use <i>No Hold</i> if you want your messages displayed as quickly as possible.
<i>New Line</i>	Forces a line break. Use <i>New Line</i> in place of a carriage return when you want text to appear on a new line.
<i>New Page</i>	Acts as a page break.
<i>Animation</i>	Preset animations that can be displayed on most signs. For example, selecting <i>Cherry Bomb</i> displays a firecracker with a burning fuse. When the fuse burns down, the bomb explodes.
<i>String...</i>	Inserts a text string in a message. See "How to use real-time data in a message" on page 103.
<i>Ticker Symbol...</i>	Inserts stock market symbols into a message. Future use.

Table 19: Message Editor



Menu Item	Description
<p><i>Options (continued)</i></p> <p>NOTE: Some options may not be available on a sign. See “Appendix D — Display Options available on signs” on page 140.</p>	<p><i>Variable...</i></p> <p>A variable does not stand for anything specific until a message is transmitted. For example, if you run a food shop which features a daily special, then a variable is an easy way to change your special:</p> <p>First, a variable called <i>Today's special</i> is placed at the start of a message:</p>  <p>Next, a second variable called <i>Special price</i> is placed at the end of the message:</p>  <p>The message looks like this:</p>  <p>Finally, each time the message is transmitted, you will be prompted to enter text for both variables:</p> 
<i>Counter</i>	Inserts a minute, hour, or day counter in a message. For more information, see “How to edit a counter file” on page 81.
<i>Graphic...</i>	Inserts bitmapped (BMP format) images into a message. For more information, see “Creating a graphic” on page 66.
<i>Gif...</i>	Inserts images into a message in GIF format. For more information, see “Creating a GIF” on page 77.
<i>Flick...</i>	Displays a number of bitmapped image files on a sign which gives the illusion of movement. For more information, see “Creating a flick” on page 71.
<i>Message...</i>	Inserts an entire message into the current message you are editing.

Table 19: Message Editor

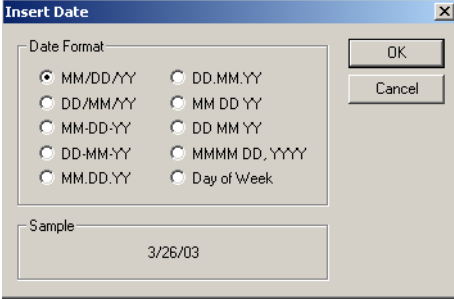
Menu Item		Description
<i>Snippet</i>	<i>Capture...</i>	After highlighting some text in a message, select <i>Capture</i> to store the text in one of 5 snippets. This is a handy way to avoid retyping commonly-used text. When you need to use that text, simply place the cursor in the message where you want it to appear and then click the snippet that holds that text to paste it.
	<i>Snippet 1</i>	
	<i>Snippet 2</i>	
	<i>Snippet 3</i>	
	<i>Snippet 4</i>	
	<i>Snippet 5</i>	

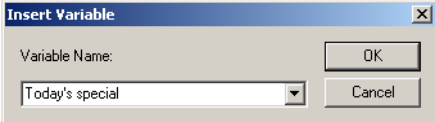

<i>View</i>	<i>Toolbar</i> <i>Status Bar</i>	<p>Checking <i>Toolbar</i> displays these icons.</p>  <p>Checking <i>Status Bar</i> displays informative text on this line.</p>
	<i>Codes</i>	<p>When <i>Codes</i> is checked, the modes, characters, and options icons will appear in a message.</p>  <p>When <i>Codes</i> is not checked, only text will appear in a message.</p> 

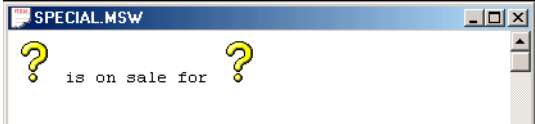
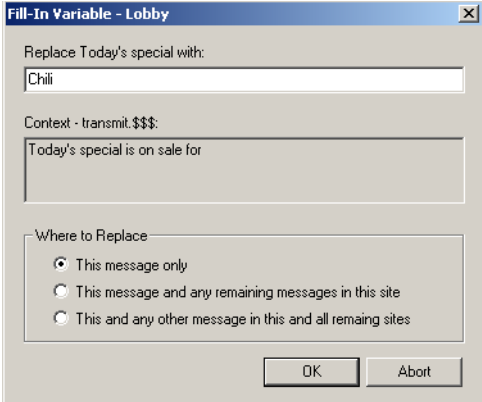
Table 19: Message Editor

Menu Item		Description
<i>Window</i>	<i>Cascade</i>	These are standard Windows® software methods of arranging windows and icons on the screen.
	<i>Tile</i>	
	<i>Arrange Icons</i>	
	<i>1 Alpha 1</i>	These are the names of the message windows you have opened. Select a window to make it the current window.

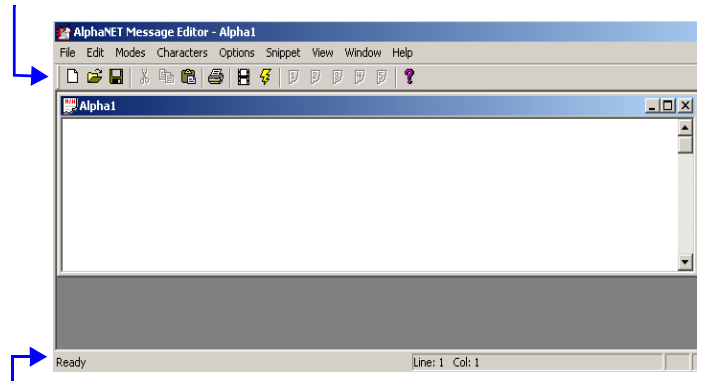
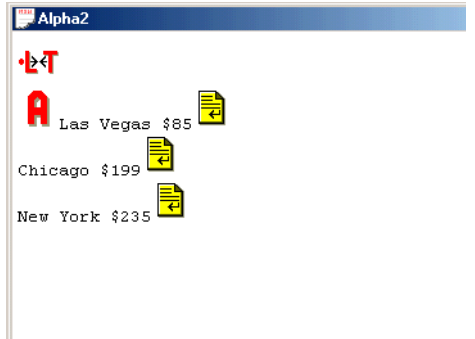

Site Manager

Site Manager is used to set up devices, sites, and groups. Devices are methods of communicating with signs. For example, a modem is a device because it talks to a sign through signals sent over a telephone line.

Sites and groups are terms used to describe how messages are sent to signs. You create sites and groups to make sending messages to multiple signs flexible and easy.

For more information, see “Step-by-step tutorial in setting up connection devices, sites, and groups” on page 17.

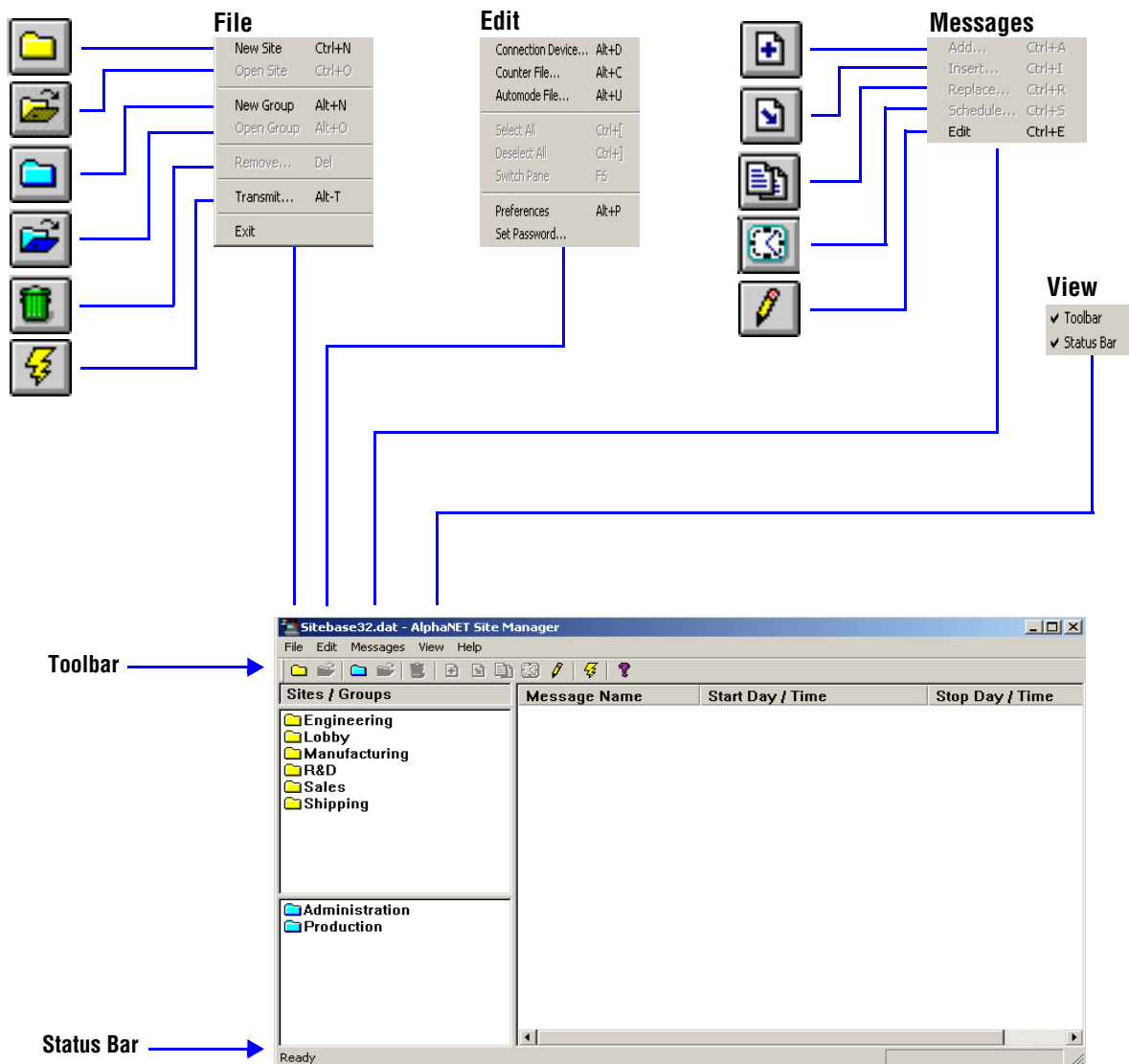

Table 20: Site Manager

Menu item		Description
<i>File</i>	<i>New Site</i>	<p>Creates a new site using four tabs of setup information:</p> <ul style="list-style-type: none"> <p><i>Site Info</i> (see “Step-by-step tutorial in setting up connection devices, sites, and groups” on page 17):</p> 
		<ul style="list-style-type: none"> <p><i>Sign Info</i> (see “Step-by-step tutorial in setting up connection devices, sites, and groups” on page 17):</p>  <p><i>Automode File</i> and <i>Tune File</i> are available only if <i>Compatibility</i> on the <i>Site Info</i> tab is set to <i>Alpha 2.0</i>.</p>

Table 20: Site Manager



Menu item	Description
<p><i>File</i></p> <p><i>New Site</i> (continued)</p>	<ul style="list-style-type: none"> <p><i>Group Info</i> (see “Step-by-step tutorial in setting up connection devices, sites, and groups” on page 17):</p> 
	<ul style="list-style-type: none"> <p><i>Advanced</i> (see “Step-by-step tutorial in setting up connection devices, sites, and groups” on page 17):</p> <p><i>Offsets</i> allows you to correct for time zone and temperature differences. For example, if you are sending messages from the Central Standard Time zone to a sign located in the Eastern Time zone (which is 1 hour ahead), you would enter an offset of +01:00.</p> <p><i>Delayed Send Options</i> permits you to delay transmitting messages to a sign. This is useful if you are using a modem to send messages late at night to take advantage of lower phone rates.</p> <p><i>Dimming Options</i> allows you to dim a sign’s LEDs by a specified percentage at a specific time. (This option can only be used with AlphaEclipse™ and Solar™ outdoor signs. However, the brightness percentage cannot be used with a Solar™ sign.)</p>  <p><i>Memory Configuration</i> (see “How to use real-time data in a message” on page 103).</p>

Table 20: Site Manager

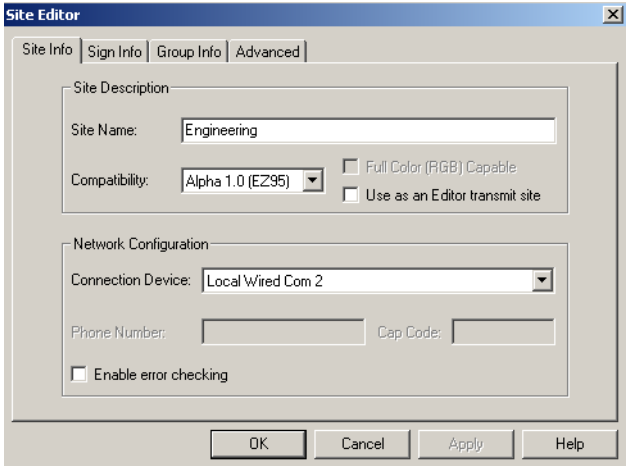
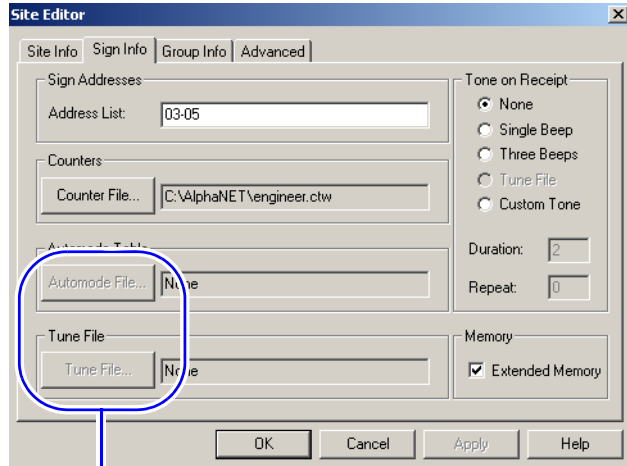
Menu item	Description
<i>Connection Device...</i>	<p>Ways to connect a sign to a PC that is running AlphaNET™ 3.0 software. There are four types of connection devices: direct cable (local), modem (remote), wireless, and Local Area Network (LAN).</p> <p>For more information, see “Step 1: Creating or changing the connection devices” on page 19.</p>
<i>Counter File...</i>	<p>Sets up from 1 to 5 numerical counters which can be used in messages or to trigger the display of other messages.</p> <div data-bbox="787 548 1300 642" data-label="Image"> </div> <p>The counter in this message counts up to 50 days then restarts from 0.</p> <p>For more information, see “How to edit a counter file” on page 81.</p>
<i>Automode File...</i>	<p>One or more files can be created so that a message can cycle through a customized list of selected modes.</p> <div data-bbox="906 856 1182 1108" data-label="Image"> </div>
<i>Select All</i>	<p>If you have a message selected from the message list, then all messages in the list are selected. The same applies to sites and groups.</p>
<i>Deselect All</i>	<p>The opposite of <i>Select All</i>.</p>
<i>Switch Pane</i>	<p>There are three panes in the <i>Site Manager</i> window (see below). Selecting <i>Switch Pane</i> moves from the current pane to another pane.</p> <div data-bbox="678 1310 1414 1793" data-label="Image"> </div>
<i>Preferences</i>	<p>Allows you to save run times for recently added messages.</p>
<i>Set Password</i>	<p>Allows you to password-protect <i>Site Manager</i>.</p>

Table 20: Site Manager

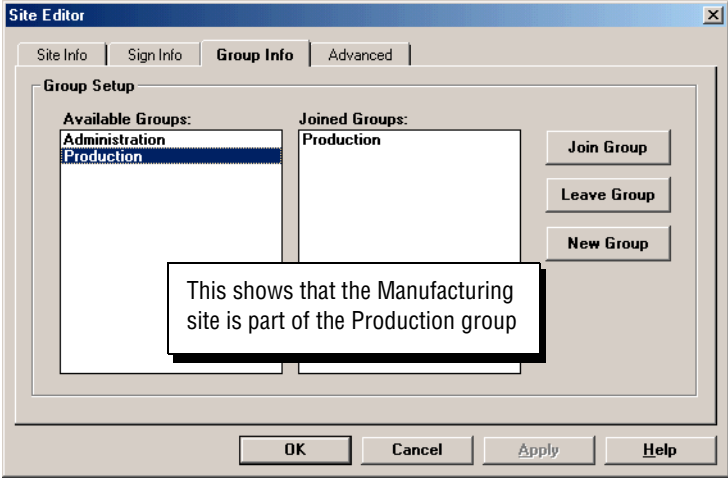
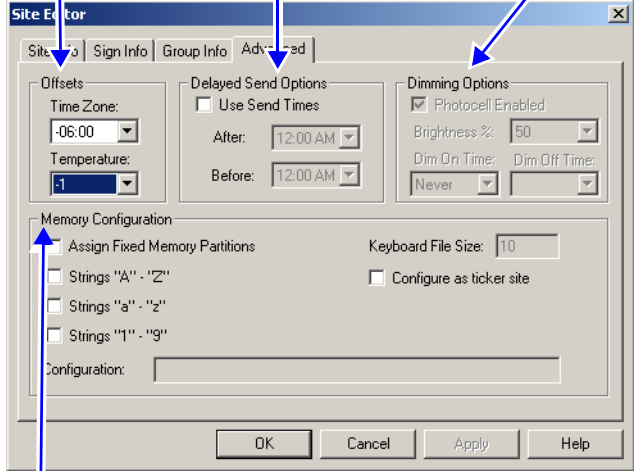
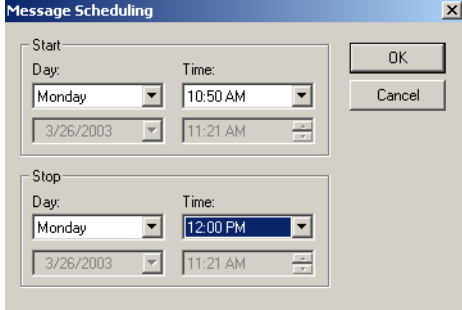
Menu item		Description
<i>Messages</i>	<i>Add...</i>	Adds a message to the end of the current message list.
	<i>Insert...</i>	Inserts a message above the message that is currently selected.
	<i>Replace...</i>	Replaces the message currently selected with another message of your choice.
	<i>Schedule...</i>	<p>Sets the times when a message appears on a sign:</p>  <p>In this example, the message will display every Monday from 10:50 a.m. to 12:00 p.m.</p> <p>Note: Sites that have <i>Compatibility</i> on the <i>Site Info</i> tab set to <i>Alpha 2.0</i> can schedule messages using dates. Select <i>Date</i> for the start day to activate a calendar.</p>
<i>Edit</i>		Opens the selected message in <i>Message Editor</i> .

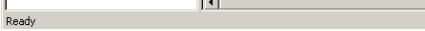
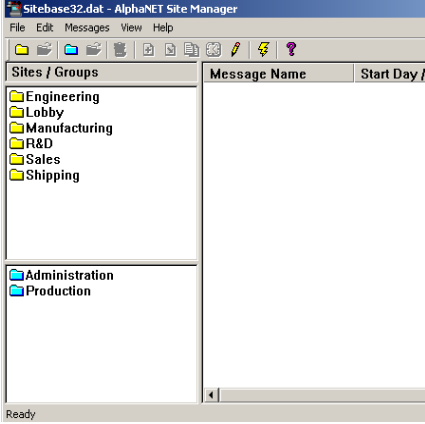
<i>View</i>	<p><i>Toolbar</i></p> <p><i>Status Bar</i></p>	<p>Checking <i>Toolbar</i> displays these icons. </p> <p>Checking <i>Status Bar</i> displays informative text on this line. </p> 
-------------	------------------------------------------------	-----------------------------------------------------------------------------------------------------------------------------------------------------------------------------------------------------------------------------------------------------------------------------------------------------------------------------------------------------------------------------------------------

Communications Manager

Communications Manager keeps track of messages you send to signs and reports on transmission errors. When a message is transmitted, it goes through *Communications Manager* before going to a sign.

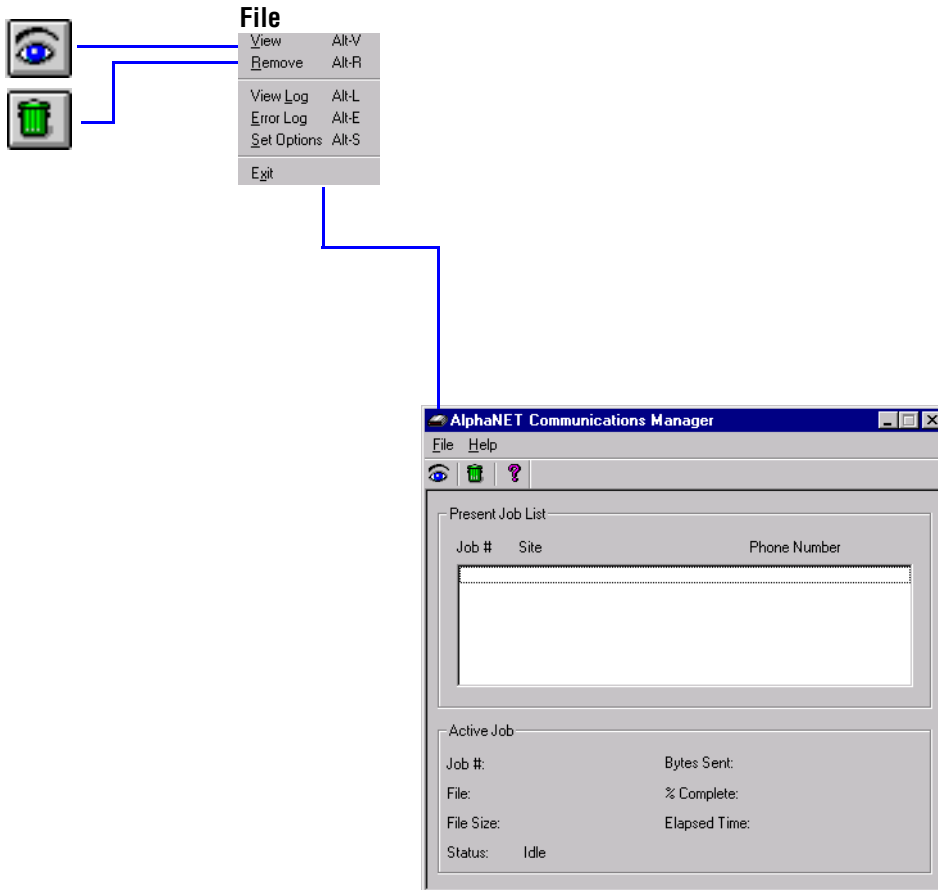
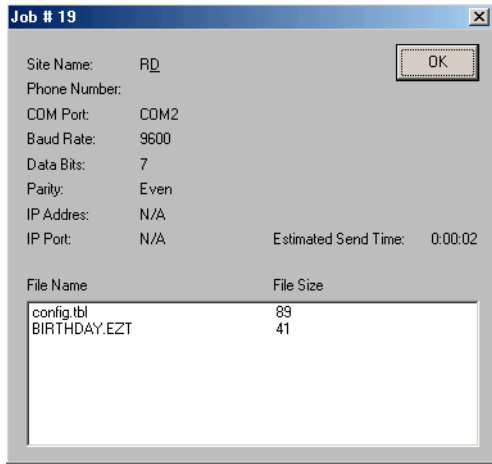
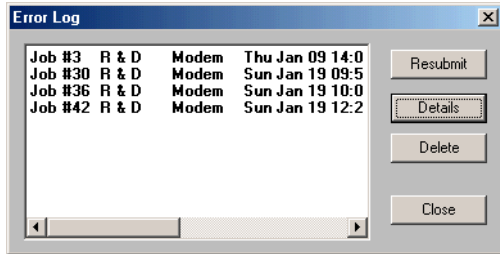
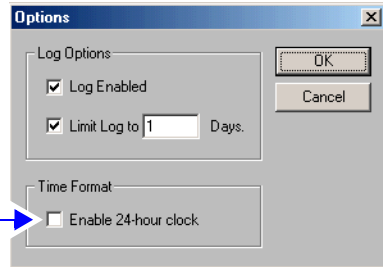

Table 21: Communications Manager

Menu item		Description
<i>File</i>	<i>View</i>	<p>Allows you to see the status of messages being transmitted to a site:</p>  <p>The screenshot shows a dialog box titled "Job # 19" with fields for Site Name (RD), Phone Number, COM Port (COM2), Baud Rate (9600), Data Bits (7), Parity (Even), IP Address (N/A), and IP Port (N/A). It also displays an Estimated Send Time of 0:00:02 and a table of files: config.tbl (89) and BIRTHDAY.EZT (41).</p>
	<i>Remove</i>	Removes selected messages from the job list. When this is done, the removed messages do not appear.
	<i>View Log</i>	Shows all items sent each day and creates a log file for each day's items.
	<i>Error Log</i>	<p>Shows the message error log which is a list of failed message transmissions. Use <i>Resubmit</i> to resend a failed transmission, <i>Details</i> to see the details of a particular transmission, and <i>Delete</i> to remove a job.</p>  <p>The screenshot shows an "Error Log" dialog box with a table listing failed jobs: Job #3, Job #30, Job #36, and Job #42, each with its status (R & D), modem, and timestamp. Buttons for Resubmit, Details, Delete, and Close are visible.</p>
	<i>Set Options</i>	<p>Use to enable or disable saving the log file. You can also set how many days of log files will be saved. This is useful if you have limited disk space. Also, a 24-hour time format (00:00 to 23:59 instead of using AM or PM) can be set for all signs.</p> <p>When this is checked, all signs will display the time in 24-hour format (for example, 13:00 instead of 1:00 PM).</p>  <p>The screenshot shows the "Options" dialog box with "Log Enabled" and "Limit Log to 1 Days" checked. The "Enable 24-hour clock" checkbox is unchecked, and a blue arrow points to it from the text above.</p>
	<i>Exit</i>	Quits <i>Communications Manager</i> .



Diagnostics

Diagnostics allows you to test the functions of a single Alpha® sign or a network of Alpha® signs. Diagnostics can:

- transmit messages or beeps to a sign.
- receive specific information (serial address, firmware version, time, temperature, and so on) from a sign.
- set specific information (date, time, temperature, and so on) on a sign.
- reset a sign.
- clear a sign's memory.

Diagnostics can only be launched through the *Start* menu (*Start>Programs>AlphaNET>Diagnostics*). Any changes you make within the Diagnostics application will be saved and appear the next time you open it.

For the best diagnostic result, perform one Diagnostics function at a time. A log file, which contains a record of each function Diagnostics is asked to perform, is automatically created and stored in the same directory as the software itself.

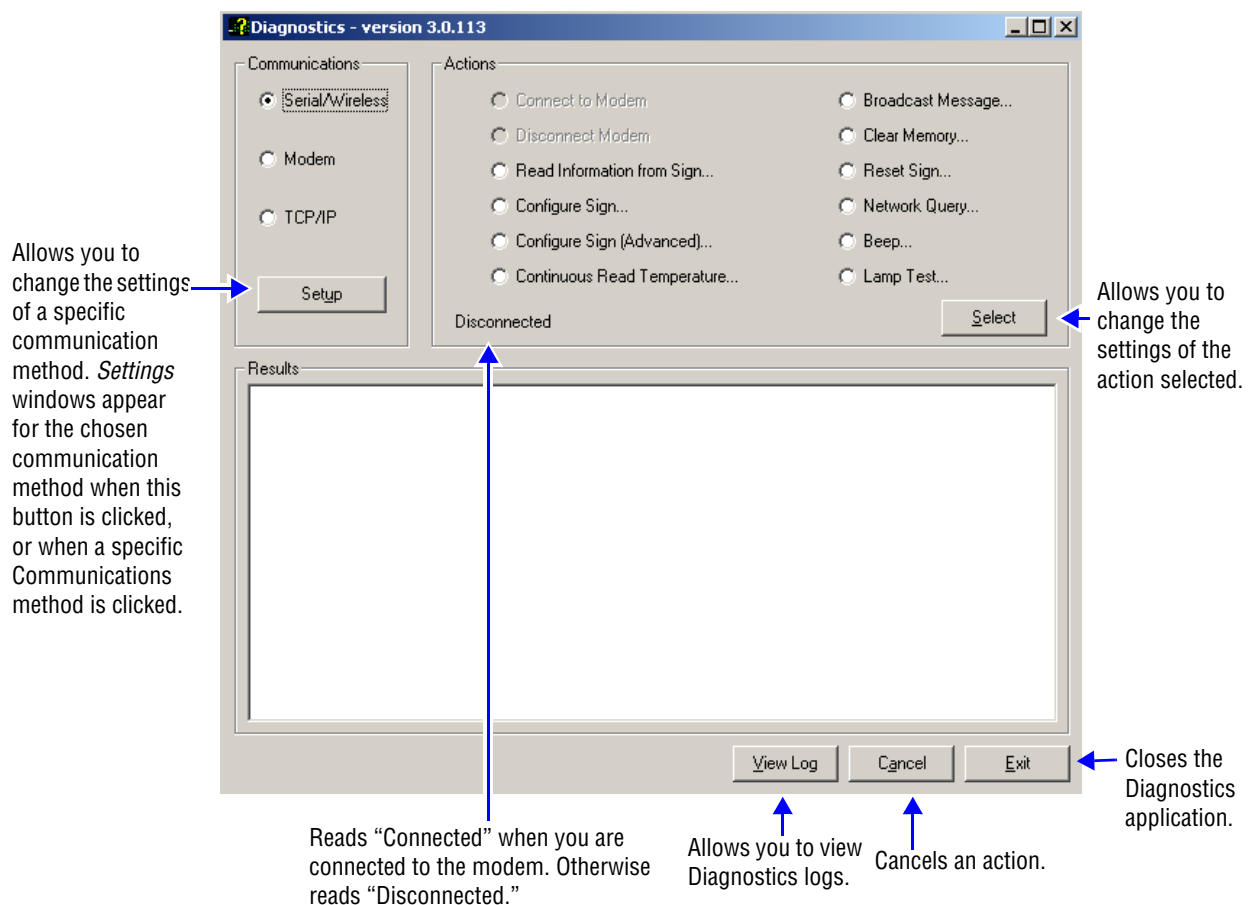

Each action in Diagnostics requires that you select the address of the signs on which you want information. To do this, click the **Select Address** button when it appears:

It is generally better and much faster to retrieve information when you specify the address of a particular sign or signs rather than choosing all addresses.

Select *Selected Addresses* and then use the *Address to Add to List* drop-down menus to specify the address of the sign on which you want information. Then click *Add*. Repeat for each sign address.

Note that the addresses must be added in hexadecimal.

The screenshot shows a dialog box titled "Select Addresses". It has a close button in the top right corner. There are two radio buttons: "All Addresses" (which is selected) and "Selected Addresses". Below the radio buttons is a section labeled "Address to Add to List:" containing two dropdown menus for "Address:" (both showing "0") and an "Add" button. Below this is a large empty list box labeled "Address List:". At the bottom of the list box are "Remove All" and "Remove Last" buttons. At the very bottom of the dialog are "OK" and "Cancel" buttons. A blue arrow points from the "Selected Addresses" radio button to the text on the left. Another blue arrow points from the "OK" button to the text below it.

Click *OK* when done.

Table 22: Diagnostics

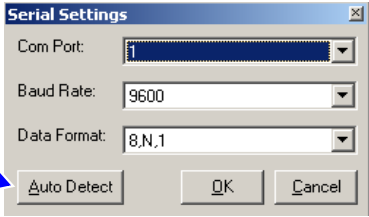
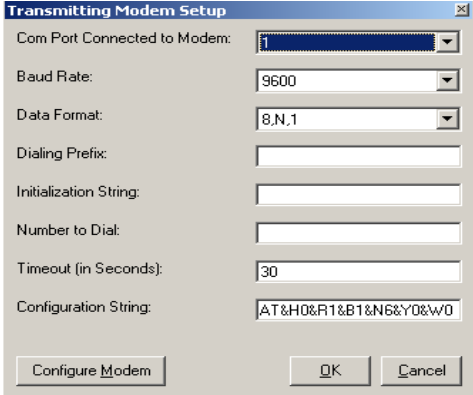
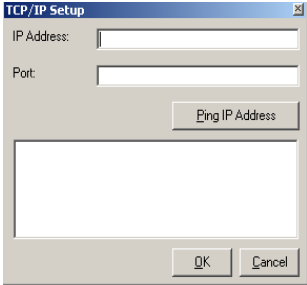
Menu item		Description
<i>Communi- cations</i>	<i>Serial/Wireless</i>	<p>Use the drop-down menus to set the COM port, baud rate, and data format for a serial or wireless connection:</p> <p>Click here if you want AlphaNET™ to determine this information for you.</p> 
	<i>Modem</i>	<p>Complete the information for the transmitting modem for a modem connection:</p> 
	<i>TCP/IP</i>	<p>Fill in the IP Address and Port information for a TCP/IP connection:</p> 
<i>Actions</i>	<i>Connect to Modem</i>	Connects Diagnostics to the receiving modem in your sign.
	<i>Disconnect Modem</i>	Disconnects Diagnostics from the receiving modem in your sign.

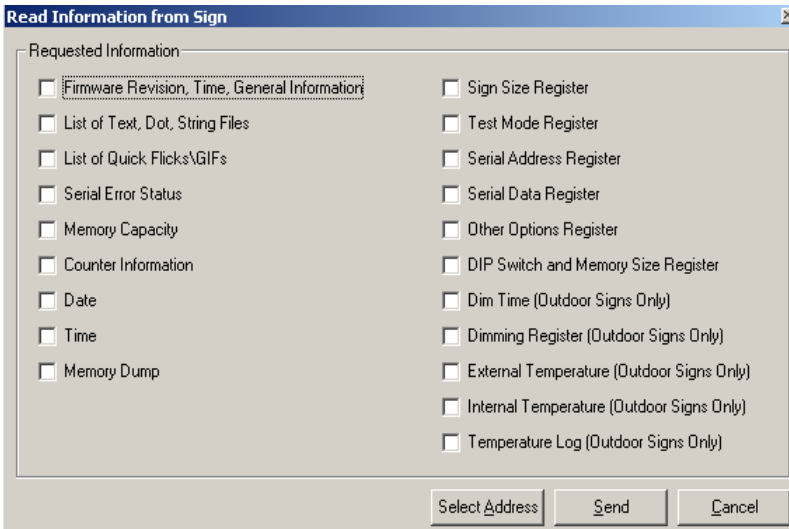
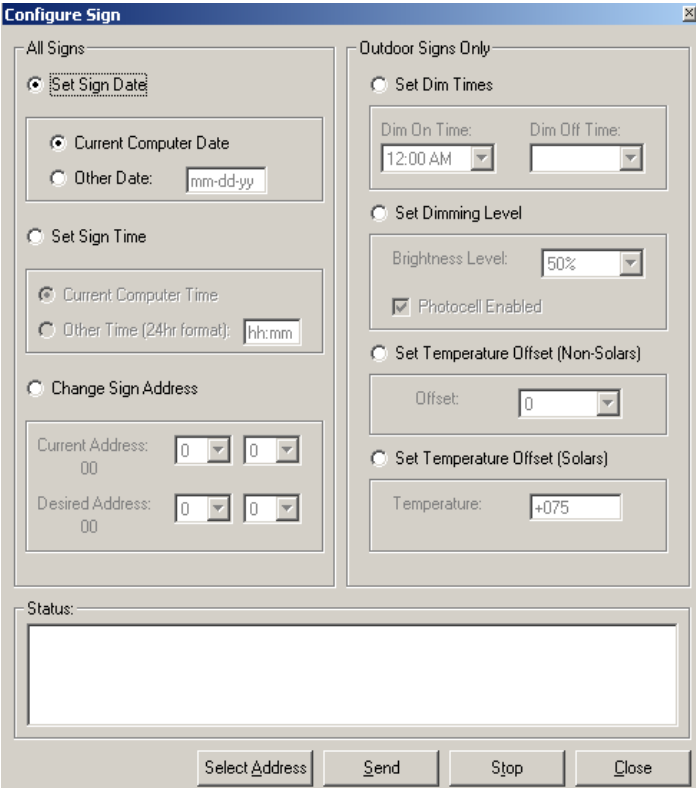
Menu item		Description
	<p><i>Read Information from Sign</i></p>	<p>Displays the information you can request from a sign.</p>  <p>Select the information you want Diagnostics to retrieve by clicking the appropriate boxes, and then select the sign addresses. When finished, click <i>Send</i>.</p>
<p><i>Actions</i></p>	<p><i>Configure Sign</i></p>	<p>Allows you to set specific information on a sign.</p>  <p>Complete the appropriate information and then select the sign addresses. When finished, click <i>Send</i>. Use the <i>Status</i> area to view a log of the connection.</p> <p>Click <i>Stop</i> when you want to stop the transmission before its completion.</p>

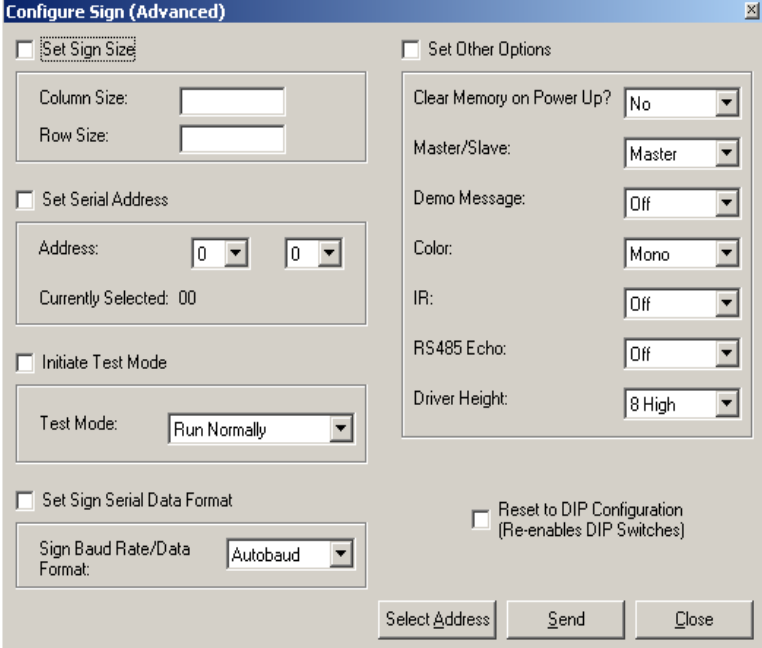
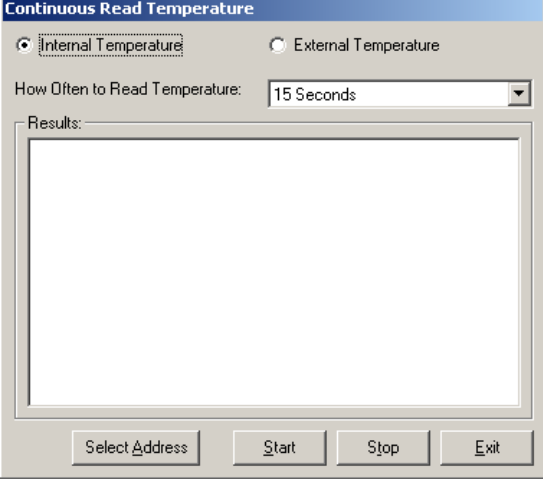
Menu item	Description
<p><i>Actions</i></p> <p><i>Configure Sign (Advanced)</i></p>	<p>Allows you to set additional specific information on a sign.</p>  <p>Complete the information you want Diagnostics to set, and then select the sign addresses. When finished, click <i>Send</i>.</p>
<p><i>Continuous Read Temperature</i></p>	<p>Allows you to continually check a sign's internal or external temperature.</p>  <p>Select which temperature Diagnostics should check, then use the drop-down menu to choose how often. Finally, select the sign addresses. When finished, click <i>Start</i>. Use the <i>Results</i> area to view a log of the temperatures.</p> <p>Click <i>Stop</i> when you want to stop the transmission.</p>

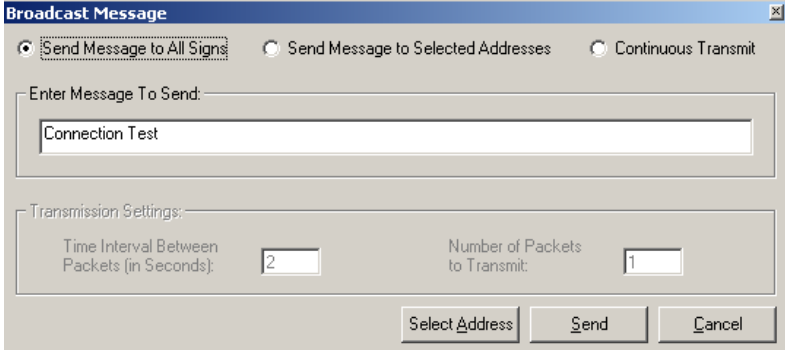
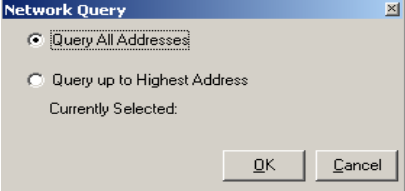
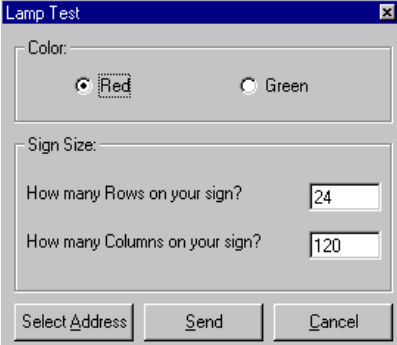
Menu item	Description
<i>Actions</i>	<p>Allows you to send a message to one or more signs, or to continually send a series of messages to one or more signs.</p>  <p>Set up the broadcast message and then the transmission settings, and then select the sign addresses. When finished, click <i>Send</i>.</p>
	<p><i>Clear Memory</i></p> <p>Deletes all text and DOTS files from a sign. Choose the sign addresses in the Select Addresses window that appears and click <i>OK</i>.</p>
	<p><i>Reset Sign</i></p> <p>Restarts a sign. Choose the sign addresses in the Select Addresses window that appears and click <i>OK</i>.</p>
	<p><i>Network Query</i></p>  <p>Choose whether you want to check all addresses or up to the highest address, and then click <i>OK</i>.</p>
	<p><i>Beep</i></p> <p>Sends three short beeps to a sign. Choose the sign addresses in the Select Addresses window that appears and click <i>OK</i>.</p>
<p><i>Lamp Test</i></p>  <p>Indicates whether any LEDs have burned out in a sign.</p> <p>Set the appropriate information and then select the sign addresses. When finished, click <i>Send</i>.</p>	
<i>Results</i>	<p>Information about an action Diagnostics performs is logged here.</p>

THIS PAGE INTENTIONALLY BLANK

5

Appendix

Appendix A — Macintosh® computer setup

The following instructions describe how to use a Macintosh® computer running Virtual PC¹ with AlphaNET™ 3.0 software.

Required software and hardware

Table 23: Required software

Qty	Part #	Description
1	—	Macintosh® G4 computer
1	—	Virtual PC ¹ for Macintosh® (This emulates Windows® 98, ME, and 2000 software.)
¹ Available from MacWarehouse (800-255-6227).		

Single sign connection

Table 24: Single sign connection

Item	Part #	Description
A	—	This can be either an: Alpha® 200, 300, 4000, or 7000 series, AlphaVision™, Big Dot®, BetaBrite®, Director™, Solar™, or PPD™ (Personal Priority Display) sign.
B	10888625	25-foot 6-conductor RS232 data cable
	10888627	50-foot 6-conductor RS232 data cable
C	43700001C	25 pin sub-D/to 6 pos. RJ11 adapter
D	—	DB25-to-DIN8 hardware handshake modem cable (Supra Corporation, 800-727-8772, part # 33-2025-PL).

Multiple sign connection

Since there are a number of ways to network signs, see the **Networking Alpha Signs** manual (pn 97000112).

Appendix B — Modes available on signs

Modes are special effects used to change the way a message appears on a sign and are used in *Message Editor*:



Open *Message Editor* and click the *Modes* drop-down menu.

Available only on the AlphaEclipse™ PureColor™ 3600 Series sign.

Sign	Modes																							
	Automode	Flash	Hold	Interlock	Roll		Rotate		Scroll	Slide		Snow	Sparkle	Spray	Starburst	Switch		Twinkle	Wipe		Cycle Color	Clock	Explode	
					Up/Down/Left/Right	In/Out (horizontal)	In/Out (vertical)	Standard		Condensed	Slide					Slide -> Cycle Color	Switch half the display		Up/Down/Left/Right	In/Out (horizontal)				In/Out (vertical)
200 Series	●	●	●	●	●	●	●	●	●	●	●	●	●	●	●	●	●	●	●	●	●	●	●	●
220C	●	●	●	●	●	●	●	●	●	1	1	●	●	●	●	●	●	●	●	●	●	●	●	●
300 Series	●	●	●	●	●	●	●	●	●	●	●	●	●	●	●	●	●	●	●	●	●	●	●	●
420C	●	●	●	●	●	●	●	●	●	1	1	●	●	1	●	●	●	●	●	●	●	●	●	●
4000 Series	●	●	●	●	●	●	●	●	●	●	●	●	●	●	●	●	●	●	●	●	●	●	●	●
7000 Series	●	●	●	●	●	●	●	●	●	●	●	●	●	●	●	●	●	●	●	●	●	●	●	●
Big Dot®	●	●	●	●	●	●	●	●	●	●	●	●	●	●	●	●	●	●	●	●	●	●	●	●
AlphaVision™ (Full Matrix)	●	●	●	●	●	●	●	●	●	●	●	●	●	●	●	●	●	●	●	●	●	●	●	●
AlphaVision™ (Char Matrix)	●	●	●	●	●	●	●	●	●	●	●	●	●	●	●	●	●	●	●	●	●	●	●	●
790i, 430i, 440i, 460i	●	●	●	●	●	●	●	●	●	●	●	●	●	●	●	●	●	●	●	●	●	●	●	●
Solar™	●	●	●	●	●	●	●	●	●	●	●	●	●	●	●	●	●	●	●	●	●	●	●	●
BetaBrite®	●	●	●	●	●	●	●	●	●	●	●	●	●	●	●	●	●	●	●	●	●	●	●	●
Director™	●	●	●	●	●	●	●	●	●	●	●	●	●	●	●	●	●	●	●	●	●	●	●	●
PPD™	●	●	●	●	●	●	●	●	●	●	●	●	●	●	●	●	●	●	●	●	●	●	●	●
AlphaEclipse™	●	●	●	●	●	●	●	●	●	●	●	●	●	●	●	●	●	●	●	●	●	●	●	●
AlphaPremiere™	●	●	●	●	●	●	●	●	●	●	●	●	●	●	●	●	●	●	●	●	●	●	●	●

¹If the *Slide* mode is selected for either the 220C or 420C sign, the *Cycle Color* mode will be used instead. The same applies to the *Spray* mode for the 420C sign only.

Table 25: Mode descriptions

Mode	Function
Automode	This is the default mode, which actually consists of using all other modes available to each sign. If no other mode is selected, the message will appear in automode.
Flash	All characters flash off and on from the point of <i>Flash</i> mode until the point where another mode is selected, if any.
Hold	Holds the message or specified text in a fixed place for several seconds.
Interlock	Alternating rows of dots enter from each direction on a sign and interlock to form the message in the center of the sign.
Roll	Rolls the characters in the message in their entirety onto the sign in the desired direction. You can choose to roll up, down, left, right, in, or out.
Rotate	Rotates a message from right to left across the sign without stopping. For certain signs, text can be condensed or standard.
Scroll	Moves the message one line at a time from the bottom to top of the sign. The previous line is pushed off the sign.
Slide	The message moves onto the sign from one direction to the other, one character at a time.
Snow	The dots of each character in the message fall randomly onto the sign as if it is snowing.
Sparkle	The message sparkles onto the sign by randomly filling the letters of the message (at the start of the message display only).
Spray	The message is sprayed onto and across the sign, left to right, column by column, and character by character.
Starburst	Random starbursts explode over and around letters of the message on the sign.
Switch	Alternating characters of the message slide onto the sign from different directions. In other words, the first character slides up, the next down, and so on. For some signs, instead of alternating characters switching, one half of the message on the sign slides up while the other half of the message slides down.
Twinkle	The message appears in its entirety in a twinkling effect with lights flickering off and on for the duration of the message display.
Wipe	The message is wiped onto the sign in the direction specified, filling in each of the characters row by row or column by column. It looks as if it is washing over the old message. You can choose to roll up, down, left, right, in, or out.
Cycle Color	Colors cascade through the message from the bottom up.
Clock	The message is wiped off and then on the display as if a second hand were sweeping around it.
Explode	The message rolls from the center of a display outward in all four directions at once.

Appendix C — Character fonts and colors available on signs

AlphaNET™ 3.0 software allows you to change the character shapes and colors that are used in messages. The *Characters* option and colors are used in *Message Editor*:

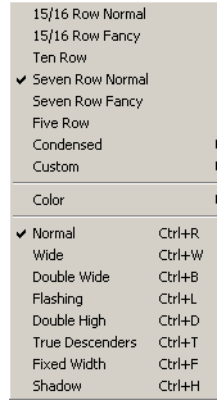

Open *Message Editor* and click the *Characters* drop-down menu.

The *Condensed* and *Custom* characters allow selection of 15/16 Row, Ten Row, Seven Row, or Five row in condensed or customized format. To use them, custom fonts must be installed in the sign's memory outside of the AlphaNET™ 3.0 software.

Available only on the AlphaEclipse™ PureColor™ 3600 Series sign.

Sign	Characters														
	15/16 Row Normal	15/16 Row Fancy	Ten Row	Seven Row Normal	Seven Row Fancy	Five Row	Color (see NOTE)	Normal	Wide	Double Wide	Flashing	Double Height	True Descenders	Fixed Width	Shadow
200 Series				●	●	●	●	●	●	●				●	
220C				●	●	●	●	●	●	●	●			●	
300 Series				●	●	●	●	●	●	●	●			●	
420C				●	●	●	●	●	●	●	●			●	
4000 Series	●	●		●	●	●	●	●	●	●	●			●	
7000 Series	●	●	●	●	●	●	●	●	●	●	●	●	●	●	
Big Dot®				●	●	●	●	●	●	●	●			●	
AlphaVision™ (full matrix)	●	●	●	●	●	●	●	●	●	●	●	●	●	●	
AlphaVision™ (character matrix)				●		●	●	●			●				
790i, 430i, 440i, 460i				●		●		●	●	●				●	
Solar™	●	●		●	●	●	●	●	●	●	●			●	
BetaBrite®				●	●	●	●	●	●	●	●			●	
Director™				●		●	●	●			●				
PPD™				●	●	●		●	●	●	●			●	
AlphaEclipse™	●	●		●	●	●		●	●	●	●			●	●
AlphaPremiere™	●	●	●	●	●	●	●	●	●	●	●	●	●	●	

NOTE: Sign names ending in "C", such as 4120C, have color capabilities. Sign names ending in "R", such as 4120R, can display in red only.

Appendix D — Display Options available on signs

Options is a *Message Editor* menu composed of special features, such as animation, and is used by AlphaNET™ 3.0 software to enhance the way a message appears on a sign:

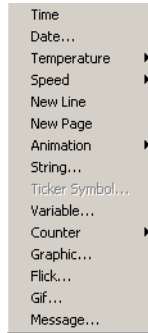

Open Message Editor and click the Options drop-down menu.

Not available on an AlphaEclipse™ PureColor™ 3600 Series sign.

Sign	Options															
	Time	Date	Temperature		Speed	New Line	New Page	Animation	String	Ticker Symbol	Variable	Counter	Graphic (see NOTE)	Gif (see NOTE)	Flick (see NOTE)	Message
			Fahrenheit	Celsius												
200 Series	●	●			●	●		●	●	●	●	●				●
220C	●	●			●	●		●	●	●	●	●				●
300 Series	●	●			●	●		●	●	●	●	●				●
420C	●	●			●	●		●	●	●	●	●				●
4000 Series	●	●			●	●		●	●	●	●	●				●
7000 Series	●	●			●	●	●	●	●	●	●	●	●	●	●	●
Big Dot®	●	●			●	●		●	●	●	●	●				●
AlphaVision™ (full matrix)	●	●			●	●	●	●	●	●	●	●	●	●	●	●
AlphaVision™ (character matrix)	●	●			●	●	●	●	●	●	●					●
790i, 430i, 440i, 460i	●		●	●	●	●		●	●	●	●	●				●
Solar™	●	●	●	●	●	●		●	●	●	●	●				●
BetaBrite®	●	●			●	●		●	●	●	●	●				●
Director™	●	●			●	●		●	●	●	●					●
PPD™	●	●			●	●		●	●	●	●	●				●
AlphaEclipse™	●	●	●	●	●	●		●	●	●	●	●	●	●		●
AlphaPremiere™	●	●			●	●	●	●	●	●	●	●				●

NOTE: A graphic, gif, or flick must be designed for the resolution of the sign. For example, a 4120C sign has a resolution of 120 columns by 16 rows. Therefore, in order to fit on a 4120C, an image can be no greater than 120 x 16 pixels in size.

Appendix E — Understanding message line positions (Top, Middle, Bottom, Fill)

Line position refers to where a message is displayed on a sign — the top, middle, bottom, or fill. Line position is available with most modes, such as *Hold*, *Snow*, or *Sparkle*.

An example of line position follows:

Line Position: How the message appears in the *Editor*:

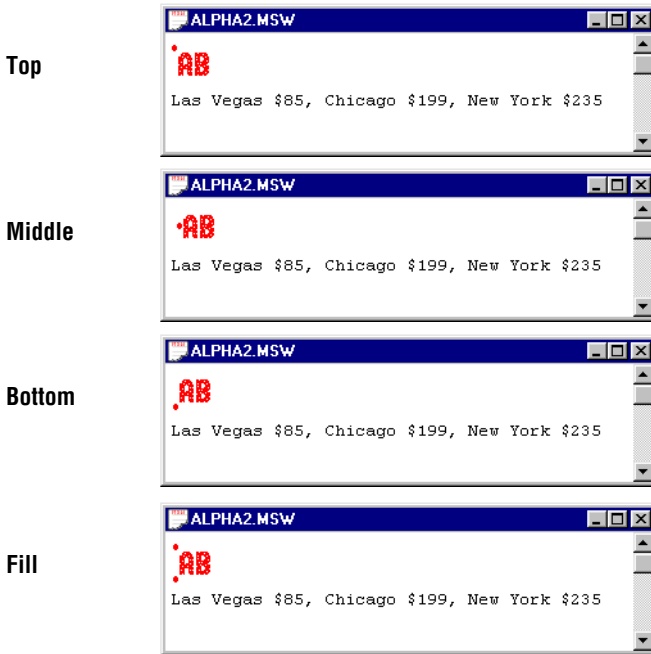

How the message appears on a 2-line sign:



If you do not select one of these four positions, an Alpha® sign will automatically display your message using the *Automode* mode and the *Fill* line position.

When you use the *Fill* line position, the sign will try to fill both lines with the message.

Types of signs

Signs are categorized by number of lines of text.

- Single-line (BetaBrite®, 215R & 215C, 220, 300 series, 400 series, Big Dot®) — These signs are of varying lengths but are always 7 dots high.
- Two-line (4000 series) — These signs are of varying lengths but are always 16 dots high.
- Three-line (7000 series) and multiple-line full matrix (AlphaVision™) — These signs are of varying heights and widths.
- Multiple-line character matrix (AlphaVision™, Director™).

- These signs are of varying heights and widths, but have character blocks with spaces between.

Single-line signs (BetaBrite®, 215R & 215C, 220, 300 series, 400 series, Big Dot®)

On a single-line sign, all characters line up at the bottom of the sign and work their way up as many dots as the font supports. For example:



Exception conditions:

- If the sign receives a font that is larger than the sign can display, it will size it down.
- 7-high normal characters are substituted for any 15-high normal characters.
- 7-high fancy characters are substituted for any 15-high fancy characters, and so on.
- If a graphic is received that is taller than the display can show, the top seven rows are displayed.
- If a graphic is received that is wider than the display can show, it will show the left-most columns of the picture.
- If a graphic is received that is smaller than seven dots tall, it will be displayed from the bottom of the sign up, similar to the 5-dot character set shown above.
- If a character set is not established in the message, 7-high normal characters are used.
- If top, bottom, or fill positions are received, middle is used.

Two-line signs (4000 series)

Top position

On a double-line sign, the *Top* position is defined as the top 7 dots of the sign and operates in the same manner as a one-line sign. See exception conditions for a single-line 7-row sign.

Bottom position

The *Bottom* position is defined as the bottom 7 dots of the sign and is treated as a one-line sign. See exception conditions for a for a single-line 7-row sign.

Middle position

The *Middle* position is treated as though it were one line of 16 dots. Each line of text presented on that line is prescanned to determine the largest piece of text (or graphic object) to be displayed. The line of text is then vertically centered based on the largest object. For example, if you have a line of text which has mostly 5-high characters, but has one 10-high character, the line is viewed as a 10-row high line, and since this is a 16-row sign, that leaves 6 extra rows — 3 blank rows on the top and 3

blank rows on the bottom. All text and objects are then lined up to this new virtual bottom (the 13th line) and treated the same as in a single-line sign.

Exception conditions:

- If the sign receives a font that is larger than the sign can display, it will size it down. On this sign, in the middle position, the only characters that are too large are characters using the double-high control code. This control code is ignored.
- If a graphic is received that is taller than the display can show, the top sixteen rows are displayed.
- If a graphic is received that is wider than the display can show, it will show the left-most columns of the picture.
- If a character set is not established in the message, 16-high normal characters are used.

Fill position

On a 4000 series sign, the *Fill* position indicates that you want to use no more than 7-high characters and that you want to fit as much text on the screen as you can. When in this mode, the sign views itself as having two lines of 7-high characters and no means of handling a character set larger than 7-high. If a graphic is selected, at most seven rows of that graphic will be displayed. If the last piece of text to be displayed (towards the end of the message) is only one line of text, the sign will place 4 blank rows of dots at the top and the bottom of the text in order to center the last line of text vertically.

If the sign is operating on the top row, the bottom of that row is assumed to be the 7th row of dots. All text is started from there and worked up. (5-row characters will use rows 3 – 7, while 7-row characters will use rows 1 – 7.)

If the sign is operating on the bottom row, it works its way up from row 16. (5-row characters will use rows 12 – 16, while 7-row characters will use rows 10 – 16.)

Exception conditions:

- If the sign receives top, bottom, or fill modes and also a font that is larger than 7-high, it will size it down. 7-high normal characters are substituted for any 15-high normal characters. 7-high fancy characters are substituted for any 15-high fancy characters received, and so on.
- If a graphic is received that is taller than 7 rows high (15-high for the *Middle* position), the top 7 rows (top 15 for the *Middle* position) are displayed.
- If a graphic is received that is longer than the display can show, it will show the left-most columns of the picture.
- If a character set is not established in the message, 7-high normal characters are used.

Triple-line (7000 series) and AlphaVision™ Full Matrix

Top/Bottom

These two positions work together. There is an imaginary line between the top half and the bottom half of the display. We will call this line the centerline. In the example below, the centerline is between the *Hello* and the *lots of text about basically*. The centerline divides what is used on the sign for top position commands from what is used for bottom.



Establishing the position of the centerline

The centerline position is typically established by the first top command received and the rest of the space is used for the bottom. If the bottom command comes first, the centerline is placed at its highest possible position, row 8, allowing for one line of 7-dot characters on the top. If the top command comes first, and not the bottom, the centerline's position is determined by the amount of text following the position command.

Examples:

- If one 7-dot high line of text is received (following a top command), the centerline will be fixed at row 8.
- If one line of 10-dot characters is received (following a top command), the centerline will be placed at position 11.
- If two lines of 5-dot high characters are received (following a top command), the centerline is placed at row 12 (5 for each line of text, plus the 2 blank rows between the lines).

Two exceptions to the above rules are as follows:

- The centerline is never placed higher than 8 rows from the top of the sign.
- The centerline is never placed lower than 8 rows from the bottom of the sign. This ensures that there is always room for one line of 7-dot high characters on the top or bottom (including one blank row).

Once its position is established, the centerline remains fixed at that position until a *Fill* or *Middle* position command is received. All subsequent top or bottom position commands use the amount of space set by the position of the centerline. You cannot change the position of the

centerline with a second top/bottom command. For example:

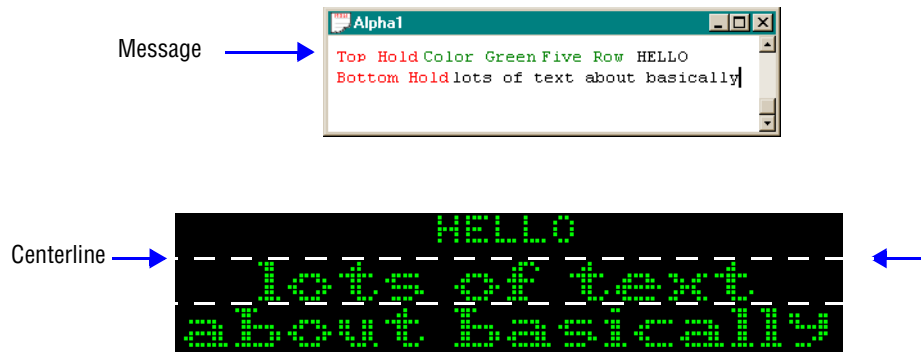

Middle position

The *Middle* position is treated as though it were one line as many dots high as the sign is tall. Each line of text presented on that line is prescanned to determine the largest piece of text (or graphic object) to be displayed. The line of text is then vertically centered based on that largest object. For example, if you have a line of text which has mostly 5-high characters, but has one 10-high character, the line is viewed as a 10-row high line. Assuming this is a 24-row sign, that would leave 14 extra rows — 7 blank rows on the top and 7 blank rows on the bottom. All text and objects are then lined up to this new virtual bottom (the 21st line) and treated the same as in a single line sign.

Exception conditions:

- If a graphic is received that is larger than what the display can show, the top-most rows are displayed.
- If a graphic is received that is longer than the display can show, it will show the left most columns of the picture.
- If a character set is not established in the message, 7-high normal characters are used.

Fill position

On a 7000 series or AlphaVision™ sign, the *Fill* position indicates that you wish to fit as much text on the screen as you can. On these signs, as opposed to the 4000 series, you can select character sets larger than 7-high in the *Fill* position. The sign will start from the top of the screen working down. If you select a 15-row character set, the sign will fit as many 15-row lines of text on the screen as possible. As soon as the sign detects that the next line will not fit, it will stop creating the current page and display it. The next page will begin with the line that would not have fit. If the text does not use up the entire display, the sign will center the text vertically, splitting the blank space between the top and the bottom.

Exception conditions:

- If a graphic is received that is taller than seven rows high, the top seven rows are displayed.
- If a graphic is received that is wider than the display can show, it will show the left-most columns of the picture.

- If a graphic is received that is smaller than seven dots tall, it will be displayed from the bottom of the sign up, similar to the 5 dot character set explained above.
- If a character set is not established in the message, 7-high normal characters are used.

AlphaVision™ Character Matrix sign

This sign works exactly like the three-line (7000 series) and AlphaVision™ Full Matrix signs, with the following exceptions.

Exception conditions:

- If a mode other than *Wipe* is received, it is replaced with *Hold*.
- An AlphaVision™ sign ignores any of the following: graphics, any character set command except 5- and 7-high normal wide, double-wide, double-high, true descenders, proportional spacing, and animations.
- If a character set is not established in the message, 7-high normal characters are used.

Appendix F — How text and graphics are displayed on signs

Each sign is made up of a display area of columns and rows of LED pixels that can be turned on and off and that can display different colors (for color signs).

Columns and rows make up a sign

For example, a 4120C (or 4120R) sign has a total display area of 120 x 16:

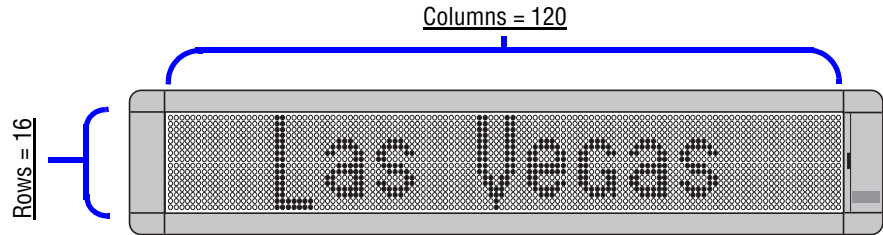

Table 26: The number of columns and rows in signs

Sign		Display area (col x rows)	Colors
BetaBrite®	1-line sign	80 x 7	8
Big Dot®	1-line sign	80 x 7	
215 Series	215R or C	90 x 7	
220	220C	2 lines of 120 x 7	1
300 Series	320C or R	120 x 7	8
	330C or R	180 x 7	
4000 Series	4080C or R	80 x 16	3
	4120C or R	120 x 16	
	4160C or R	160 x 16	
	4200C or R	200 x 16	
	4240C or R	240 x 16	
7000 Series	7080C	80 X 24	3
	7120C	120 x 24	
	7160C	160 x 24	
	7200C	200 x 24	
Outdoor displays	790i	90 x 7	1
	Solar™ series	96 x 16 to 192 x 16	1
	AlphaEclipse™	various	1
AlphaVision™	Display areas from 128 x 32 to 256 x 128.		3
Director™	8 lines of 16 characters		8
PPD™	2 lines of 120 x 7		1
AlphaPremiere™ Series	9080C or R	80 x 32	3
	9120C or R	120 x 32	
	9160C or R	160 x 32	
	9200C or R	200 x 32	
	9240C or R	240 x 32	
NOTE: Sign names ending in "C", such as 4120C, have color capabilities. Sign names ending in "R", such as 4120R, can display in red only.			

Text comes in four basic sizes

The *Characters* menu contains a list of available text sizes, such as *15/16 Row Normal* and *Ten Row*, and options such as *Wide* and *Flashing*:

Text sizes are selected from the *Characters* menu. (The default text size is *Seven Row Normal*.)

Other text options can also be selected here.

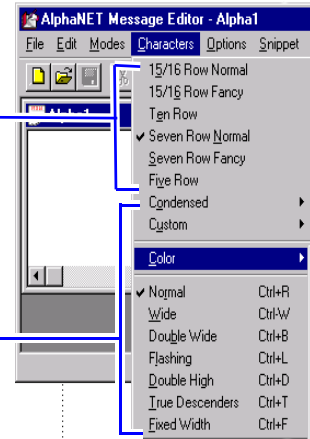

The four basic text sizes are 15/16 Row (Normal and Fancy), Ten Row, Seven Row (Normal and Fancy), and Five Row. These are also available in compressed form. Customized variations can be installed into the sign's firmware and accessed in the software.

Below are examples of how the message *Las Vegas \$85, Chicago \$199* would appear on a two-line 4120C or 4120R sign in all four basic text sizes (except Ten Row):

15/16 Row Normal

Characters are 15 or 16 rows high and about 9 columns wide:

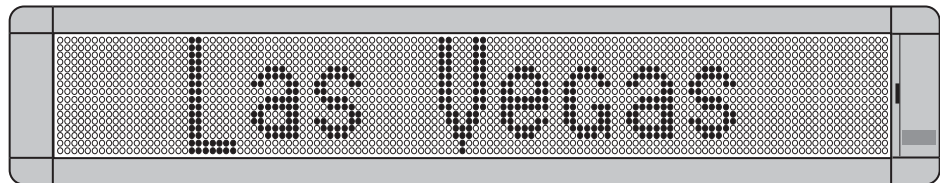

Seven Row Normal

Characters are 7 rows high and about 6 columns wide:

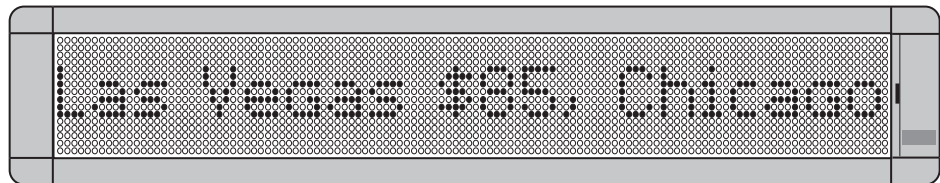

Five Row

Characters are 5 rows high and about 5 columns wide:

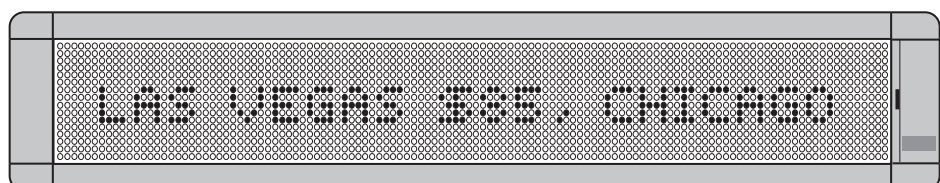

Graphics must be bitmapped to a sign's columns and rows

Before you create a bitmap image for a sign, you must first know the display area of that sign. (See “Columns and rows make up a sign” on page 147).

The columns and rows that make up a sign's display area also represent the maximum pixel size of an image that can be put on the sign. For example, a 4120C (or 4130R) sign has a total display area of 120 columns x 16 rows. This means that the largest image a 4120C could display would be 120 pixels long x 16 pixels high:



A graphic may be too big for some signs

Because signs vary in size, make sure the images you create can fit on all your signs:



Though this 32 x 16 pixel bitmap fits easily on a two-line 4120C sign, only the top part appears on a one-line 215C sign.

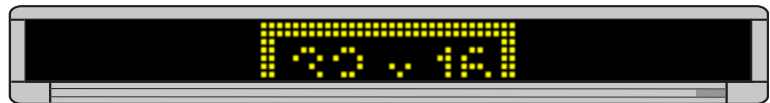

A graphic may be the wrong color for some signs

Only sign names ending in “C” have color capabilities such as the 4120C. Sign names ending in “R”, like the 4120R, can only display red:

4120C
(a multi-color sign)



4120R
(a red-only sign)

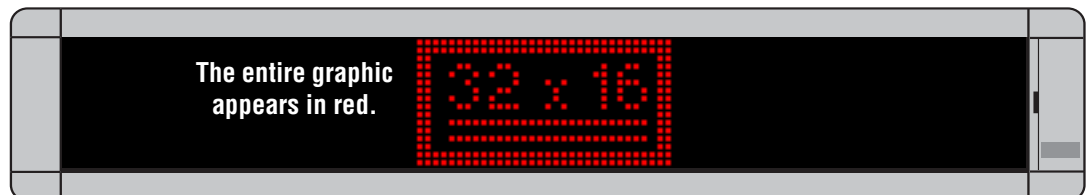

Paint Shop Pro — an image editor

At a minimum, the program you use should have a zoom feature which allows you to magnify the image you are editing because images used on signs are typically 32 x 32 pixels or less in size. (That’s very small!)

You will need a program to create and edit bitmapped images. Image editing software examples in this manual illustrate version 5.03 of Paint Shop Pro (the steps are similar for newer versions of Paint Shop Pro).

The latest version of Paint Shop Pro is available from Corel at www.corel.com. They typically offer a 30-day demonstration version. However, there is a number of programs designed for editing graphics. You can search for “open source graphic program” or freeware or shareware to get started.

While there are many great commercial programs available, you may not need all their features—or want to pay the price for them.

Paint Shop Pro has many features, including a zoom.

Paint Shop Pro has many functions including a zoom feature which can magnify small images.

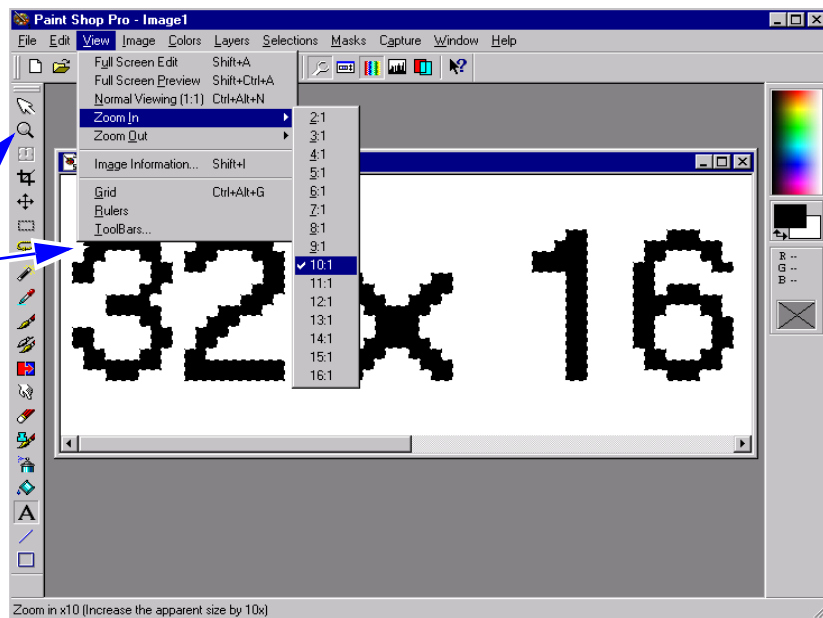

Where can you get a copy of Paint Shop Pro?

- World Wide Web
<http://www.corel.com/>